

# GEARED REDUCER

KM helical-hypoid gear reducer

BKM helical-hypoid gear reducer

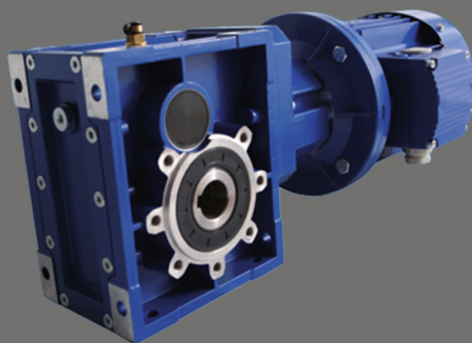

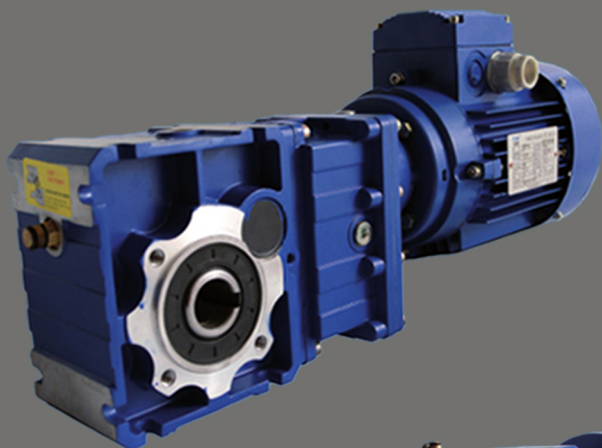

SHUNDA TRANSMISSION

## 目录/CONTENTS

### KM

产品结构 / Product structure picture	006-007
概述 / Summarize	008
型号说明 / Model illuminate	009
选型相关参数 / Relevant parameter	010-015
选型举例 / Selection example	016
减速机选型表 / Gear unit selection tables	017-021
性能参数 / Performance parameter	022-053
外型尺寸图 / Outline dimension sheet	054-057
附件 / Accessories	058
安装方位 / Installation positions	059-060
安装方法 / Installation methods	061-062

### BKM

结构分解图 / Structure diagram	064-065
设计特征 / Design features	066-067
型号说明 / Model illuminate	068
选型相关参数 / Relevant parameter	069-076
减速机型号表 / Gear unit selection tables	077-082
性能参数 / Performance parameter	083-107
外形尺寸图表 / Outline dimension sheet	108-111
连接尺寸图表 / Gonnecting dimension sheet	112-115
附件尺寸图表 / Accessories outline dimension sheet	116
安装方位图 / Installation positions diagram	117-118
润滑油 / Lubricants	119-120
维护 / Maintenance	121
存放 / Storage	122
订货须知 / Notice for order	122
运转故障 / Mulfunctions	123
减速机负载特征表 / Charge characteristic chart	124



SHUNDA TRANSMISSION

BKM 高效型准双曲面齿轮减速机 / BKM HIGH EFFICIENCY HYPOID GEAR UNITS

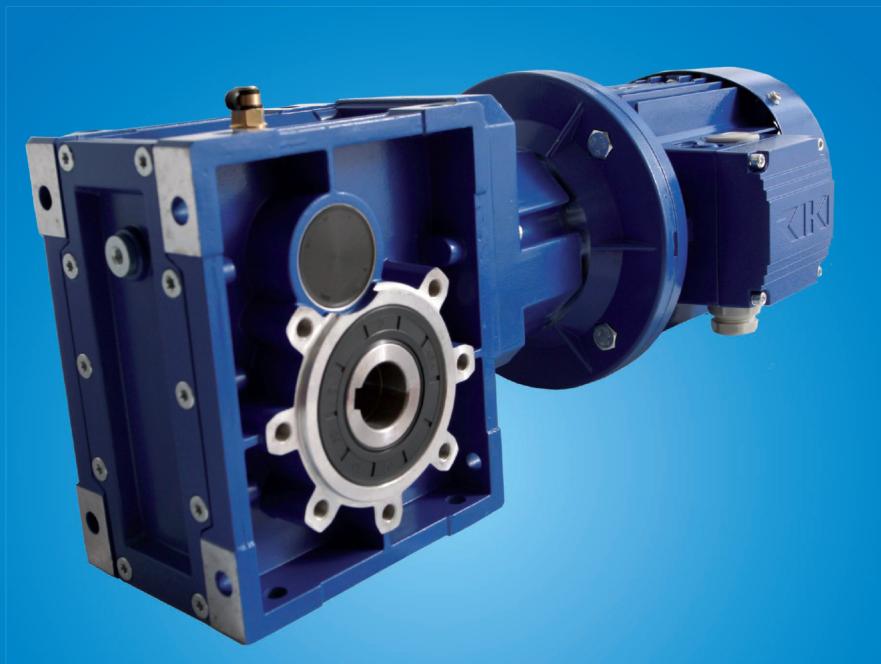



SHUNDA TRANSMISSION

# 结构分解图 / STRUCTURE DIAGRAM

结构分解图

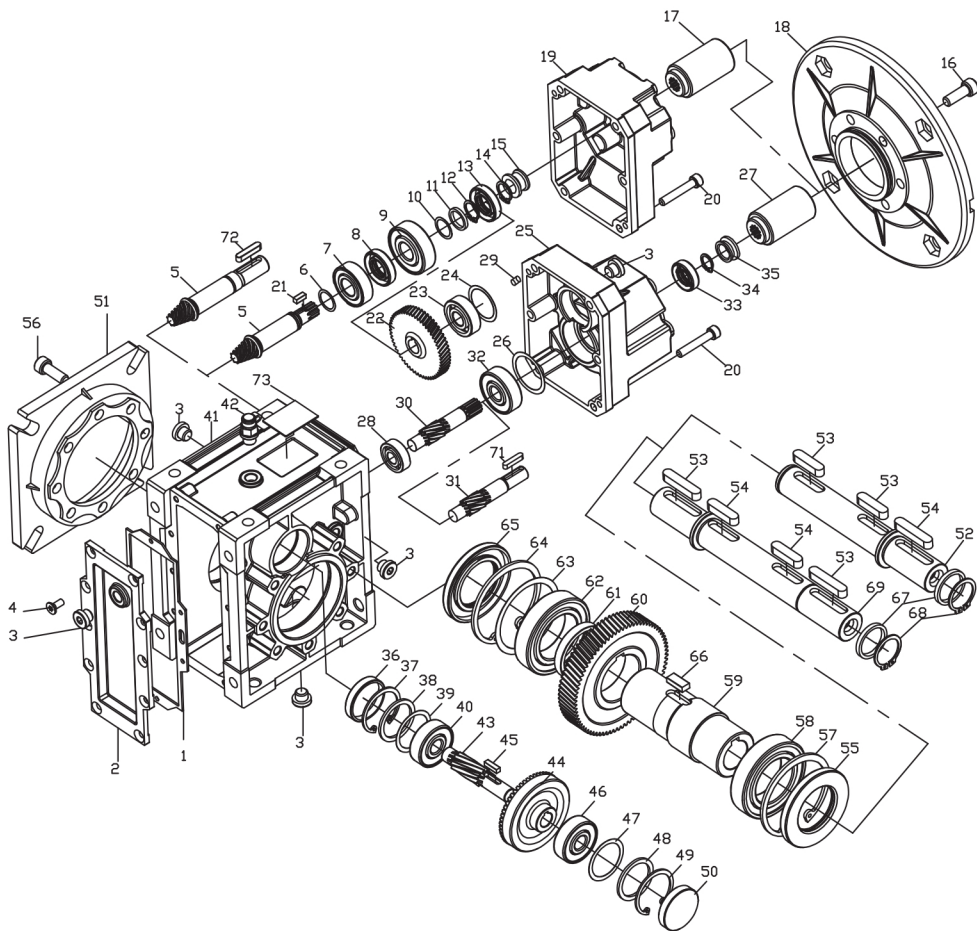



## 结构分解图 / STRUCTURE DIAGRAM

1	橡胶垫 / Rubber gasket	38	垫圈 / Washer
2	齿轮箱盖板 / Gearcase cover	39	调整垫片 / shim ring
3	油塞 / Oil plug	40	轴承 / Bearing
4	内六角沉头螺钉 / Hexagon sunk screw	41	齿轮箱体 / Gearcase
5	主动齿轮轴 / Pinion shaft	42	透气阀 / Breather valve
6	调整垫片 / shim ring	43	主动齿轮轴 / Pinion shaft
7	轴承 / Bearing	44	从动齿轮 / Gear
8	油封 / Oil seal	45	键 / Key
9	轴承 / Bearing	46	轴承 / Bearing
10	调整垫片 / shim ring	47	调整垫片 / shim ring
11	垫圈 / Washer	48	垫圈 / Washer
12	轴用挡圈 / Shaft-circlip	49	孔用挡圈 / Hole-circlip
13	油封 / Oil seal	50	油封盖 / Closing cap
14	轴用挡圈 / Shaft-circlip	51	输出法兰 / Output flange
15	橡胶套 / Rubber boot	52	单向输出轴 / Single output shaft
16	内六角螺钉 / Inner hex screw	53	键 / Key
17	输入轴 / Input shaft	54	键 / Key
18	输入法兰 / Input flange	55	油封 / Oil seal
19	两极输入箱盖 / 2 stage input box cover	56	内六角螺钉 / Inner hex screw
20	内六角螺钉 / Inner hex screw	57	孔用挡圈 / Hole-circlip
21	键 / Key	58	轴承 / Bearing
22	从动齿轮 / Gear	59	输出轴 / Hollow shaft
23	轴承 / Bearing	60	从动齿轮 / Gear
24	调整垫片 / shim ring	61	垫圈 / Washer
25	三极输入箱盖 / 3 stage input box cover	62	轴承 / Bearing
26	调整垫片 / shim ring	63	调整垫片 / shim ring
27	输入轴 / Input shaft	64	孔用挡圈 / Hole-circlip
28	轴承 / Bearing	65	油封 / Oil seal
29	圆柱销 / Stifte	66	键 / Key
30	主动齿轮 / Pinion	67	垫圈 / Washer
31	主动齿轮轴 / Pinion shaft	68	轴用挡圈 / Shaft-circlip
32	轴承 / Bearing	69	输出双向轴 / Double output shaft
33	油封 / Oil seal	70	平面密封胶 / Planar sealant
34	轴用挡圈 / Shaft-circlip	71	键 / Key
35	橡胶套 / Rubber boot	72	键 / Key
36	油封盖 / Closing cap	73	铭牌 / Nameplate
37	孔用挡圈 / Hole-circlip		



SHUNDA TRANSMISSION

## 设计特征 / DESIGN FEATURES

### 产品概述 / Summarize

BKM系列高效型准双曲面齿轮减速机是我公司在KM减速机基础上研发的新一代实用性产品，融合了国内外先进技术，在保证安装尺寸与NMRW系列蜗轮蜗杆减速机兼容的前提下，通过借鉴SEW齿轮减速机结构采用全齿轮副传动，提高了传动效率，解决了当前蜗轮蜗杆减速机传动效率低，使用寿命短等问题，在工业发展中更起到了节能降耗，绿色环保的作用。

BKM series high efficiency hypoid gearbox is a new generation of product which is based on KM Reducer, developed by our company. Fuses the advanced technology both at home and abroad. The mounting dimension of BKM the same with NMRW Series worm gearbox. Adopt gear transmission used for reference SEW helical gearbox structure to improve transmission efficiency, solved NMRW worm gearbox transmission efficiency low, service life short and etc. questions. In industrial developing BKM the role of saving energy and reducing consumption, green environmental protection.

### 结构特点 / Products characteristics

- 1、采用准双曲面齿轮传动，传动比大；
- 2、输出扭矩大，传动效率高，节能环保；
- 3、优质铝合金铸造，重量轻，不生锈；
- 4、传动平衡，噪音小，适合在恶劣环境中长期连续工作；
- 5、美观耐用，体积小；
- 6、可适应全方位安装，应用广泛，使用方便；
- 7、BKM系列减速机安装尺寸与NMRW系列蜗轮蜗杆减速机完全兼容（BKM050与NMRW050部分尺寸不同）；
- 8、模块化组合，可多种形式组合，满足各种传动条件的需求。

1. Driven by hypoid gear, has big ratios.
2. Large in output torque, high efficiency, energy saving and environmental protection.
3. Made of high-quality aluminum alloy, light in weight and non-rusting.
4. Smooth in running and low in noise, can work long time in dreadful conditions.
5. Good-looking in appearance, durable in service life and small in volume.
6. Suitable for all round installation, wide application and easy of use.
7. The mounting dimension of BKM series are compatible with NMRW series worm gear unit(A part of NMRW050 dimensions are different from BKM050).
8. Modular and multi-structure can meet the demands of various conditions.



## 设计特征 / DESIGN FEATURES

### 优势对比 / Comparative advantage

#### 1、高效节能、绿色环保 / High efficiency & energy-saving

准双曲面齿轮的啮合摩擦小，传动效率高达90%以上，与蜗轮蜗杆减速机相比效率提高10%–40%。

The hypoid gear has low friction, efficiency is as high as 90%, compared with the worm gearbox, the efficiency improved about 10%–10%.

型号 Type	传动比 Ratios [i]	输入转速 Input speed [n1]	效率 Efficiency [η]
BKM075	30.24	1400	90%
NMRW075	30	1400	60%

#### 2、强度高、寿命长 / High strength & long life

准双曲面齿轮采用优质合金材料，经表面硬化处理，采用高精度磨齿机加工成形，属硬齿面齿轮，输出扭矩大，齿轮强度与寿命远远高于蜗轮蜗杆减速机。

The hypoid gear made of high quality alloy, treated by surface hardening, and produced by high-precision grinding machine, the output torque gaer strength and life are much better than worm gearbox.

### 主要材料 / Main materials

1、外壳：铝合金（机座：050–090）；灰铸铁（机座：110）；

2、齿轮：20CrMnTi，碳氮共渗，齿面硬度58–62HRC，精磨后保持渗碳层厚度0.3–0.6mm。

1. Housing: die-cast aluminum alloy (frame size:050 to 090);  
grey cast iron (frame size:110);

2. Gear wheel: 20CrMnTi, carbonization & nitriding treatment make the hardness of gear's surface up to 58–62HRC, retain carburized layer's thickness between 0.3–0.6mm after accurate grinding.

### 表面涂装 / Surface painting

铝合金外壳：

1、先抛丸处理，再经过特种防腐处理，保持银白金属感，并耐汽油，二甲苯等有机溶剂的腐蚀。

2、磷化处理，再喷RAL7035银灰色涂料或RAL5010蓝色涂料。

Aluminum alloy housing:

1. Shot blasting and special antiseptic treatment on the aluminum alloy surface.

2. After phosphating, spray the paint RAL7035 in grey or RAL5010 in blue.



SHUNDA TRANSMISSION

# 型号说明 / MODEL ILLUMINATE

减速机 / Gear unit

电机 / Motor

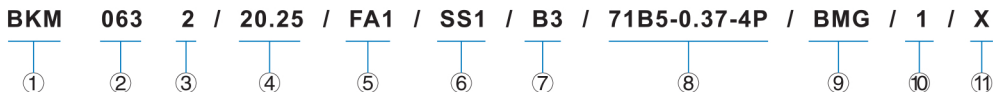

NO	说 明	Comments
1	减速机系列代号: BKM	Code for gear units series : BKM
2	减速机系列代号: 050、063、075、090、110	Specification code of gear units 050、063、075、090、110
3	1.2: 表示2级传动 2.3: 表示3级传动	1.2: Means 2 stages 2.3: Means 3 stages
	减速机速比i	Speed ratio of reducer i
4	1.无代号表示不带输出法兰 2.FA, FB, FC, FD ,FE(1/2):输出法兰代号和位置	1.No mark means without output flange 2.FA、FB、FC、FD、FE(1/2):output flange and position
6	1.无代号表示孔输出 2.SS ( 1/2 ) : 单向输出轴和位置 3.DS:双向输出轴	1.No mark means hole output 2.SS(1/2):Single output shaft and position 3.DS:Double output shaft
7	安装方位代号	Installation position code
8	1.71B5: IEC输入法兰及规格代号 2.MS7124: 紧凑型电机型号规格 3.71B5-0.37-4P:IEC输入法兰和电机功率、级数 4.56C:NEMA输入法兰及规格代号 5.ST80: 伺服电机输入法兰规格代号 6.ST80-80ST-MO1330: 伺服电机输入法兰和伺服电机型号 7.80STM-MO1330: 紧凑型伺服电机型号规格 8.HS:表示轴输入	1.71B5:IEC input flange code 2.MS7124:Compact motor type 3.71B5-0.37-4P:IEC input flange code and model motors(poles of power) 4.56C:NEMA input flange code 5.ST80:Servo motor input flange code 6.ST80-80ST-MO1330: Servo motor input flange code and servo motor type 7.80STM-MO1330:Compact servo motor type 8.HS:means shaft input
9	1.无代号表示不带制动器 2.BMG: 制动器	1.No mark means without brake 2.BMG:brake
10	电机接线盒位置, 默认位置1可以不写	Position of motor terminal box Default position 1 not to write out is ok
11	电机进线位置, 默认位置X可以不写	Coil position for motor,default position X not to write out is ok

注: 订单时请说明是否带电机, 一般按不带电机供应。

NOTE:When ordering ,you should show whether the reducers are equipped with motors,othrwise reducers aren't supplied with motors.

示例Example : **BKM0633/63.33/FA2/80B5**



## 选型相关参数 / RELEVANT PARAMETER

### 功率P / Power P

$$P_1 = \frac{P_2}{\eta} \text{ [kW]}$$

$$P_{1>} = P_1 * K \text{ [kW]}$$

$P_1$  输入功率 Input power

$P_2$  输出功率 Output power

$P_{1n}$  电机额定功率 Rated power driving motor

K 服务系数 Service factor

$\eta$  传动效率 Transmission efficiency

BKM系列减速机的效率是根据传动级数确定，2级传动效率  $\eta$  为92%，3级传动效率  $\eta$  为90%。

The efficiency of BKM gear units varies with the number of gear stages, which is 92% for 2-stage, 90% for 3-stage.

### 转速 n / Rotation speed n

$n_1$  减速机输入转速 Gear units input speed

$n_2$  减速机输出转速 Gear units output speed

若是齿轮箱外部传动装置驱动，为了优化工作条件和提高使用寿命，建议使用1400r/min或更低转速。允许输入较高的输入转速，但在这种情况下，额定扭矩 $M_2$ 会下降。

If driven by the external gearing, 1400r/min or lower rotation speed is suggested so as to optimize the working conditions and prolong the service life. Higher input rotation speed is permitted, but in this situation, the rated torque  $M_2$  will be reduced.

### 传动比i / Transmission ratio i

$$i = \frac{n_1}{n_2} \text{ [kW]}$$

传动比通常为小数，在选型表中保留两位小数。

Usually transmission ratio is decimal fraction with 2 radix point tagged in selection tables.

### 扭矩 M / Torque M

$$M_2 = \frac{9550 \cdot P_1 \cdot \eta}{n_2} \text{ [Nm]}$$

$$M_{2n>} = M_2 * K \text{ [Nm]}$$

$M_2$  输出扭矩 Output torque

$M_{2n}$  选用输出扭矩 Selected Output torque

$P_1$  输入功率 Input power

$\eta$  传动效率 Transmission efficiency

K 服务系数 Service factor



# 选型相关参数 / RELEVANT PARAMETER

## 服务系数 K / Service factor K

使用减速机时，应考虑一定的服务系数K,它是根据每天的运转时间和启停频率Z确定的。

根据惯性加速系数确定三种负载类型，在下图中可以读取实际应用的使用系数，按下图选取的服务系数必须小于或等于从性能参数表中提供的服务系数。

The effect of the driven machine on the gear unit is taken into account to a sufficient level of accuracy using the service factor K. The service factor is determined according to the daily operating time and the starting frequency Z.

Three load classifications are considered depending on the mass acceleration factor. You can read off the service factor applicable to your application in following figure. the service factor selected using this diagram must be less than or equal to the service factor as given in the performance parameter table.

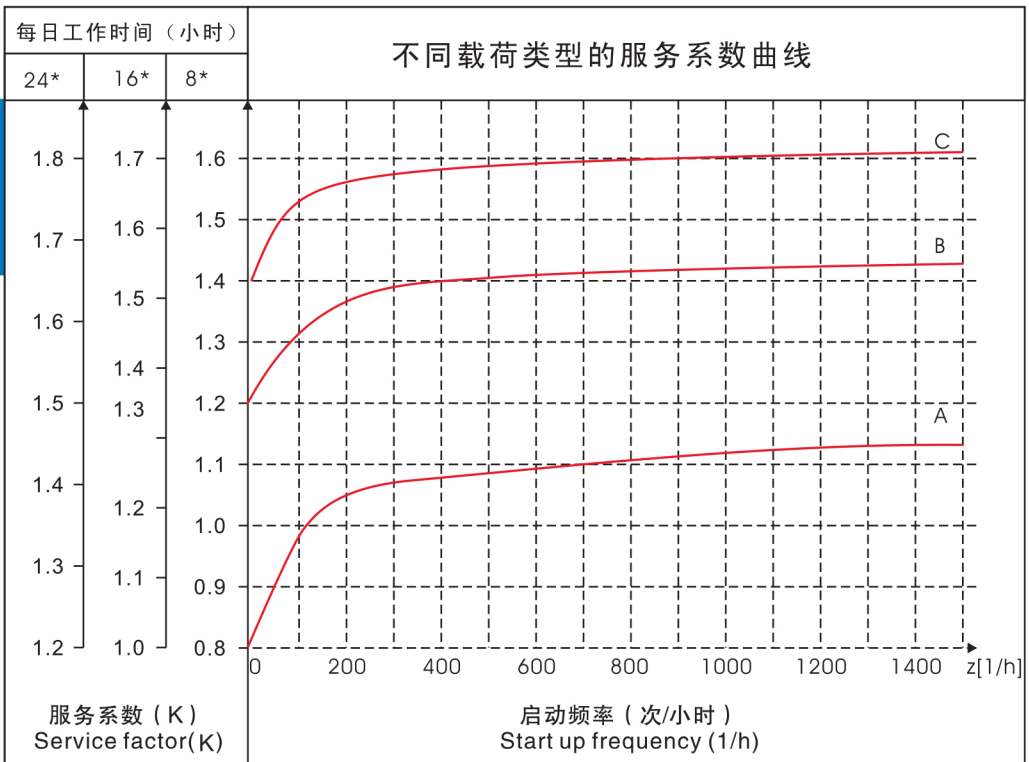

- 启动频率Z:周期包括所有启动、制动次数以及变速电机高低速度变化时的次数。
- starting frequency Z: The cycles include all starting and braking procedures as well as change overs from low to high speed .



## 选型相关参数 / RELEVANT PARAMETER

### 负载类型 / Load classifications

#### 负载性质:

- A. 均匀冲击负载, 允许惯性加速系数  $F_a \leq 0.2$   
 B. 中等冲击负载, 允许惯性加速系数  $F_a \leq 3$   
 C. 重冲击负载, 允许惯性加速系数  $F_a \leq 10$

#### Type of load:

- A. Uniform, permitted mass acceleration factor  $F_a \leq 0.2$   
 B. Moderate shock load, permitted mass acceleration factor  $F_a \leq 3$   
 C. Heavy shock load, permitted mass acceleration factor  $F_a \leq 10$

轻负载的螺杆输送, 风扇, 装备线, 输送带, 小型搅拌器, 电梯, 清洗机器, 过滤器, 控制驱动。  
 卷扬机、木工机器进料器, 货物起重机, 平衡器, 绞螺纹机器, 中型搅拌机, 重型输送带, 绞盘, 滑动闸门,  
 刮料机, 包装机械, 混凝土搅拌机、行车驱动装置, 铣床, 齿轮泵。  
 大型搅拌机, 剪床, 压机, 离心机, 旋转支持装置, 重型绞盘和起重机, 磨床, 石材打磨机, 翻斗机, 钻床,  
 冲床, 凸轴压机, 揩床, 机床转盘, 翻桶装置, 震荡装置, 破碎机。

Screw feeders for light materials, fans, assembly lines, conveyor belts for light materials, small mixers, lifts, cleaning machines, fillers, control machines.

Winding devices woodworking machine feeders, goods lifts, balancers. Threading machines, medium mixers, conveyor belts for heavy materials winches, sliding doors, fertilize scrapers, packing machines, concrete mixers crane mechanisms, milling cutters folding machines, gear pumps.

Mixers for heavy materials, shears, presses, centrifuges, rotating supports, winches and lifts for heavy materials, grinding lathes stone mills bucket elevators drilling machines hammer mills, cam presses, folding machines, turntables, tumbling barrels, vibrators shredders.

### 惯性加速系数 / Mass acceleration factor

惯性加速系数计算如下:

$$F_a = J_c / J_m$$

$F_a$  惯性加速系数

$J_c$  所有外部传动惯量 ( $\text{kgm}^2$ )

$J_m$  驱动电机的传动惯量 ( $\text{kgm}^2$ )

如果惯性加速系数  $F_a > 10$ , 请与我们技术部联系。

为了保持减速机的使用寿命, 从产品样本中所选择的服务系数  $K$  应等于或略高于计算出的服务系数  $K$ 。

The mass acceleration factor is calculated as follows:

$$F_a = J_c / J_m$$

$F_a$  Mass acceleration factor

All external mass moments of inertia ( $\text{kgm}^2$ )

$J_m$  Mass moment of inertia on the motor end ( $\text{kgm}^2$ )

If mass acceleration factors  $f_a > 10$ , please call our Technical service.

To keep the service-life of gear units, use factor  $K$  selected from the catalogue must be equal or slightly higher than the calculated use factor  $K$ .

### 举例 / Example

惯性加速系数 2.5 (负载类型 B), 运行时间 14 小时/天, (按 16 小时/天查图) 和每小时 200 次起停, 套图得服务系数  $K = 1.48$ 。根据性能参数表所选择的使用系数  $K \geq 1.48$

Mass acceleration factor 2.5 (load classification B), 14 hours/day operating time (read off at 16h/d) and 200

cycles/hour result in a service factor  $K = 1.48$ . choose the service factor  $K \geq 1.48$  according to the parameter sheet.



## 选型相关参数 / RELEVANT PARAMETER

## 径向载荷和轴向载荷 / Overhung loads and axial forces

在决定影响径向载荷时，安装在轴端上的传动件 类型必须考虑在内。不同类型的传动对应不同的传动附加系数 $f_z$ ，列表如下：

When determining the resulting radial loads, the type of transmission elements, mounted on the shaft end must be considered. Various transmission elements are corresponding with following transmission element factors  $f_z$ :

传动件 Transmission element	传动附加系数 $f_z$ Transmission element factor $f_z$	注释 Comments
齿轮 Gears	1.15	< 17齿 teeth
链轮 Chain sprockets	1.25	< 20齿 teeth
	1.40	< 13齿 teeth
V带轮 Narrow V-belt pulleys	1.75	有预紧力作用 Influence of the tensile force
平带轮 Flat belt pulleys	2.50	有预紧力作用 Influence of the tensile force
齿带轮 Toothed belt pulleys	2.50	有预紧力作用 Influence of the tensile force

作用在电机和齿轮轴上的径向载荷按如下公式计算：

The overhung loads exerted on the motor or gear shaft is then calculated as follows:

$$F_r = \frac{M \cdot 2000 \cdot f_z}{d_o} \quad [\text{N}]$$

$F_r$  作用在轴上的载荷[N] Resulting radial load [N]

$M$  作用在轴上的扭矩[Nm] Torque on the shafts [Nm]

$d_o$  安装在轴上传动件的平均直径[mm] Mean diameter of the mounted transmission element in [mm]

$f_z$  传动附加系数 Transmission element factor

许用径向载荷时根据轴承额定使用寿命 $L_{10h}$ ，来估算的(根据ISO0281)。对于特殊的运行条件，许用径向载荷时根据修正使用寿命 $L_{na}$ 来确定。

The basis for determining the permitted radial loads is the computation of the rated service life  $L_{10h}$ , of the bearings( according to ISO0281 ) For special operating conditions, the permitted radial loads can be determined with regard service life  $L_{na}$ .

当作用点偏离出轴中点时，许用径向载荷须按以下公式来计算，取在X点的许可数值 $F \times L$ (根据轴承的使用寿命)

The permitted radial loads given in the selection tables must be calculated using the following formula in the event of force application not in the center of the shaft end. The smaller of the two values  $F \times L$ ( according to bearing service life )

根据轴承的使用寿命公式 / according to bearing service life:

$$F \times L = F_{r(1,2)} \cdot \frac{a}{b+x} \quad [\text{N}]$$

$F_{r1}, F_{r2}$  =性能参数表中的许用径向载荷 (  $x=L/2$  ) [N]

Permitted overhung load (  $x=L/2$  ) for footmounted gear units according to the selection tables in [N]

$X$ =从轴肩到受力点的距离[mm] Distance from the shaft shoulder to the force application point in [mm]

$a, b$  =减速机径向转化常量[mm] Gear unit constant for overhung load conversion [mm]



# 选型相关参数 / RELEVANT PARAMETER

## ● 输出轴径向载荷 / Output shafts radial loads

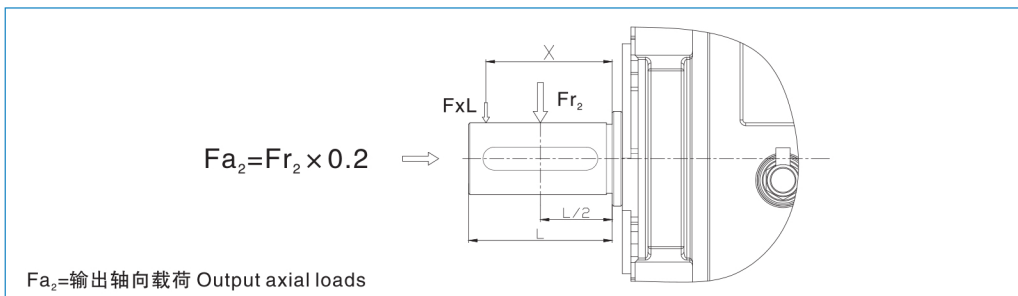

BKM减速机径向转化常量 Gear unit constants for overhung load conversion:

	BKM0502	BKM0503	BKM0632	BKM0633	BKM0752	BKM0753	BKM0902	BKM0903	BKM1102	BKM1103
a	104	104	118	118	131	131	159	159	174	174
b	78	78	93	93	101	101	119	119	134	134

选型相关参数

## ● 输入轴径向载荷 / Input shafts radial loads

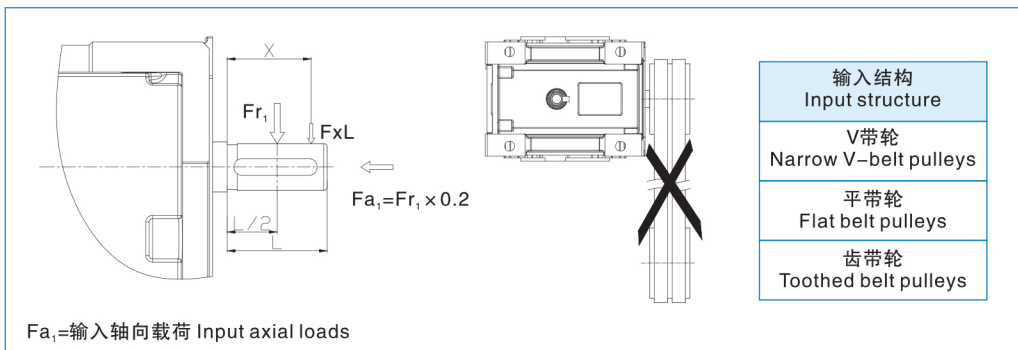

右示图的输入不被允许使用（包括三级输入）。

It is forbidden to use the input on the right chart ( Including 3 stage input).

BKM减速机径向转化常量 Gear unit constants for overhung load conversion:

	BKM0502	BKM0503	BKM0632	BKM0633	BKM0752	BKM0753	BKM0902	BKM0903	BKM1102	BKM1103
a	51.5	56	90	56	73	70	81	70	101	87
b	40	44.5	43	44.5	53	55	61	55	76	67



SHUNDA TRANSMISSION

# 选型相关参数 / RELEVANT PARAMETER

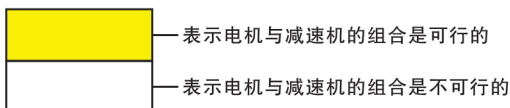

- \* 表示速比可除尽
- $P_{1n}$  电机额定功率 [kW];
- $n_2$  输出转速 [r/min];
- $M_{2n}$  输出扭矩 [Nm];
- $M_{2max}$  最大允许输出扭矩 [Nm];
- $F_{r2}$  输出轴径向载荷 [N];
- $i$  减速机公称传动比;
- $i_a$  减速机实际传动比;
- $K$  服务系数;

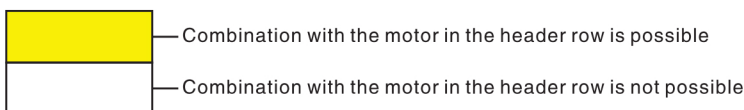

- \* Finite gear unit reduction ratio;
- $P_{1n}$  Rated power driving motor [kW];
- $n_2$  Output speed [r/min];
- $M_{2n}$  Output torque [Nm];
- $M_{2max}$  Max. permissible output torque [Nm]
- $F_{r2}$  Permissible overhung load output side [N]
- $i$  Gear unit nominal ratio;
- $i_a$  Gear unit actual ratio;
- $K$  Service factor;

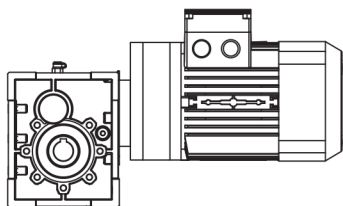

减速电机型号 Geared motor type

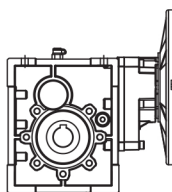

减速机型号 Gear unit type

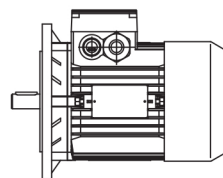

电机型号 Motor type

选型相关参数



## 选型相关参数 / RELEVANT PARAMETER

## ● 选型举例 / Selection example

## 减速电机 / Gear motor

例：被驱动设备所需要功率0.25kW，工作8小时/天，中等冲击，启动频率100次/小时，输出转速 $n_2=35r/min$ ，减速机要求B3安装，则：

$$i = \frac{n_1}{n_2} = \frac{1400}{35} = 40$$

查P8服务系数图表即可选服务系数 $K=1.3$

$$P_{in} \geq P_1 \cdot K = \frac{P_2}{\eta} \cdot K = \frac{0.25}{0.94} \times 1.3 = 0.345[\text{kw}]$$

查BKM系列性能参数表可确定减速机型号为：

**BKM0502/40.09/71B5/0.37-4P/B3**

Example: Required power 0.25kW on driven machine, work for 8h/day, moderate shock load, start up frequency 100(1/h),  $n_2=35r/min$ , B3 mounted, So:

$$i = \frac{n_1}{n_2} = \frac{1400}{35} = 40$$

Check the service factor table on page 8, choose  $K=1.3$

$$P_{in} \geq P_1 \cdot K = \frac{P_2}{\eta} \cdot K = \frac{0.25}{0.94} \times 1.3 = 0.345[\text{kw}]$$

Choose type:

**BKM0502/40.09/71B5/0.37-4P/B3**

## 减速机 / Gear units

例：被驱动设备所需扭矩为200Nm，工作8小时，均匀冲击负载，启动频率400次/小时，减速机要求FA1法兰安装，减速机要求输入转速 $n_1=900r/min$ ，输出转速 $n_2=6r/min$ ，查性能参数表可知，只选能三级传动形式。

查P8服务系数表即可选服务系数 $f_s=1$

$$i = \frac{n_1}{n_2} = \frac{900}{6} = 150$$

$$M_{2N} \geq M_2 \cdot K = 200 \times 1.05 = 210[\text{Nm}]$$

$$P_{in} \geq P_1 \cdot K = \frac{M_2 \cdot n_1}{9550 \cdot \eta \cdot i} \cdot K = \frac{210 \times 900}{9550 \times 0.92 \times 150} \times 1.05 = 0.151[\text{Kw}]$$

查BKM系列性能参数表可确定减速型号为：

**BKM0753/151.20/FA1**

Example: Required torque 200Nm on driven machine, work for 8h/day, uniform load, Start up frequency 400(1/h) FA1 mounted,  $n_1=900r/min$ ,  $n_2=6r/min$ , so the only selection is 3 stage after checked the table:

Check the service factor table on page 8, choose  $K=1$

Choose type:

**BKM0753/151.20/FA1**



## 选型相关参数 / RELEVANT PARAMETER

## ● 选型举例分析 / Selection example analysis

例：某大型企业新增一条生产流水线，需采购40台减速机，要求减速机输出功率0.8kW， $n_1=1400r/min$ ，均匀冲击负载，启动频率30次/小时，每天工作8小时，环境温度32℃，输出转速 $n_2=28r/min$ ，则：

方案一，采购传统的蜗轮减速机：

$$i = \frac{n_1}{n_2} = \frac{1400}{28} = 50$$

查看NMRW啮合参数表，估算 $i=50$ 时， $\eta_d \approx 0.68$

查看调整使用系数得 $f_s=1.05 \times 1.12=1.176$

$$P_{1n} \geq \frac{P_2}{\eta_d} \cdot K = \frac{0.8}{0.68} \times 1.176 = 1.384(\text{kW})$$

输出转矩 $M_2$ 计算：

$$M_2 = 9550 \times \frac{P_2}{n_2} = 9550 \times \frac{0.8}{28} = 272.86(\text{Nm})$$

$$M_{2n} = 379 \geq M_2 \cdot K = 272.86 \times 1.176 = 320.88(\text{Nm})$$

查NMRW系列性能参数表可确定减速机型号为：

**NMRW110/50/1.5-4P**

则生产线减速机年耗电量为(按22天/月计算)：

$$P_{1n} \times 8 \times 22 \times 12 \times 40 = 1.384 \times 8 \times 22 \times 12 \times 40 = 116920.32(\text{kW}\cdot\text{h})$$

按工业用电1.01元/kW.h计算，流水线一年的电费支出为：

$$116920.32 \times 1.01 = 118089.52 \text{ 元}$$

方案二，采购BKM高效型准双曲面齿轮减速机：

$$P_{1n} \geq \frac{P_2}{\eta_d} \cdot K = \frac{0.8}{0.94} \times 1.0 = 0.85(\text{kW})$$

输出转矩 $M_2$ 计算：

$$M_2 = 9550 \times \frac{P_2}{n_2} = 9550 \times \frac{0.8}{28} = 272.86(\text{Nm})$$

$$M_{2n} = 340 \geq M_2 \cdot K = 272.86 \times 1.0 = 272.86(\text{Nm})$$

查BKM系列性能参数表可确定减速机型号为：

**BKM0752/48.18/90B5/90S4**

则生产线减速机年耗电量为(按22天/月计算)：

$$P_{1n} \times 8 \times 22 \times 12 \times 40 = 0.85 \times 8 \times 22 \times 12 \times 40 = 71808(\text{kW}\cdot\text{h})$$

按工业用电1.01元/kW.h计算，流水线一年的电费支出为：

$$71808 \times 1.01 = 72526.08 \text{ 元}$$

选择方案二可直接节省成本支出约4.6万元。

Example : A certain large enterprise added a production line, need to purchase 40 units of gear motors. Required the output power is 0.8kw,  $n_1=1400r/min$ , uniform load, start up frequency 30(1/h), continuous running for 8 hours, the ambient temperature is 32℃.  $n_2=28r/min$ . So The first scheme, purchase traditional worm gearbox

$$i = \frac{n_1}{n_2} = \frac{1400}{28} = 50$$

Check mesh NMRW, estimate when the  $i=50$ .  $\eta_d \approx 0.68$

Check and adjust the service factor, will get

$$K = 1.05 \times 1.12 = 1.176$$

$$P_{1n} \geq \frac{P_2}{\eta_d} \cdot K = \frac{0.8}{0.68} \times 1.176 = 1.384(\text{kW})$$

count output torque

$$M_2 = 9550 \times \frac{P_2}{n_2} = 9550 \times \frac{0.8}{28} = 272.86(\text{Nm})$$

$$M_{2n} = 379 \geq M_2 \cdot K = 272.86 \times 1.176 = 320.88(\text{Nm})$$

Choose type:

**NMRW110/50/1.5-4P**

The power consumption on the production line is (22days/per month) :

$$P_{1n} \times 8 \times 22 \times 12 \times 40 = 1.384 \times 8 \times 22 \times 12 \times 40 = 116920.32(\text{kW}\cdot\text{h})$$

The power price at 1.01 yuan/kw.h, so the electric cost is 118089.52 per year

$$116920.32 \times 1.01 = 118089.52 \text{ yuan}$$

The second scheme,

purchase BKM high efficiency hypoid gear units:

$$P_{1n} \geq \frac{P_2}{\eta_d} \cdot K = \frac{0.8}{0.94} \times 1.0 = 0.85(\text{kW})$$

count output torque

$$M_2 = 9550 \times \frac{P_2}{n_2} = 9550 \times \frac{0.8}{28} = 272.86(\text{Nm})$$

$$M_{2n} = 340 \geq M_2 \cdot K = 272.86 \times 1.0 = 272.86(\text{Nm})$$

The gearbox size can be fixed from the BKM series character chart

**BKM0752/48.18/90B5/90S4**

The power consumption on the production line is (22days/per month)

$$P_{1n} \times 8 \times 22 \times 12 \times 40 = 0.85 \times 8 \times 22 \times 12 \times 40 = 71808(\text{kW}\cdot\text{h})$$

The power price at 1.01yuan/kw.h, so the electric cost is 72526.08 per year

$$71808 \times 1.01 = 72526.08 \text{ yuan}$$

Choosing the second scheme can reduce the cost at 46000 yuan.



# 减速机型号表 / GEAR UNIT SELECTION TABLES

BKM 050.. $n_1=1400r/min$						130Nm			
减速机型号 Gear units	i 公称 Nominal	i 实际 Actual	$n_2$ [r/min]	$M_{2max}$ [Nm]	$F_{r2}$ [N]	MS63	MS71	MS80	MS90
3级/Stage									
BKM0503	300	291.79	4.8	130	4100				
BKM0503	250	244.29	5.7	130	4100				
BKM0503	200	200.44	7.0	130	4100				
BKM0503	150	146.67	9.5	130	4000				
BKM0503	125	120.34	11.6	130	3770				
BKM0503	100	101.04	13.9	100	3560				
BKM0503	75	74.62	18.8	80	3220				
BKM0503	60	62.36	22	130	3030				
BKM0503	50	52.36	27	100	2860				
2级/Stage									
BKM0502	60	58.36	24	130	2960				
BKM0502	50	48.86	29	130	2790				
BKM0502	40	40.09	35	130	2610				
BKM0502	30	29.33	48	130	2350				
BKM0502	25	24.07	58	130	2200				
BKM0502	20	20.21	69	100	2080				
BKM0502	15	14.92	94	80	1880				
BKM0502	12.5	12.47	112	130	1770				
BKM0502	10	10.47	134	100	1670				
BKM0502	7.5	7.73	181	80	1510				

减速机选型表



SHUNDA TRANSMISSION

# 减速机型号表 / GEAR UNIT SELECTION TABLES

BKM 063.. $n_1=1400r/min$						200Nm			
减速机型号 Gear units	i 公称 Nominal	i 实际 Actual	$n_2$ [r/min]	$M_{2max}$ [Nm]	$F_{r2}$ [N]	MS63	MS71	MS80	MS90
3级/Stage									
BKM0633	300	302.50	4.6	200	4800				
BKM0633	250	234.57	5.7	200	4800				
BKM0633	200	196.43	7.1	180	4800				
BKM0633	150	151.56	9.2	200	4650				
BKM0633	125	122.22	11.5	180	4330				
BKM0633	100	101.27	13.8	150	4070				
BKM0633	75	73.33	19.1	110	3650				
BKM0633	60	63.33	22	180	3480				
BKM0633	50	52.48	27	150	3270				
2级/Stage									
BKM0632	60	60.50	23	200	3430				
BKM0632	50	48.71	29	200	3190				
BKM0632	40	39.29	36	180	2970				
BKM0632	30	30.31	46	200	2720				
BKM0632	25	24.44	57	180	2530				
BKM0632	20	20.25	69	150	2380				
BKM0632	15	14.67	95	110	2130				
BKM0632	12.5	12.67	110	180	2030				
BKM0632	10	10.5	133	150	1910				
BKM0632	7.5	7.60	184	110	1710				

减速机选型表



# 减速机型号表 / GEAR UNIT SELECTION TABLES

BKM 075.. $n_1=1400r/min$						350Nm				
减速机型号 Gear units	i 公称 Nominal	i 实际 Actual	$n_2$ [r/min]	$M_{2max}$ [Nm]	$F_{r2}$ [N]	MS63	MS71	MS80	MS90	
3级/Stage										
BKM0753	300	297.21	4.7	350	6500					
BKM0753	250	240.89	5.8	350	6500					
BKM0753	200	200.66	7.0	300	6500					
BKM0753	150	151.20	9.3	350	6500					
BKM0753	125	125.95	11.1	300	5980					
BKM0753	100	99.22	14.1	240	5520					
BKM0753	75	75.45	18.6	200	5040					
BKM0753	60	62.43	22	300	4730					
BKM0753	50	49.18	28	240	4370					
2级/Stage										
BKM0752	60	59.44	24	350	4660					
BKM0752	50	48.18	29	350	4340					
BKM0752	40	40.13	35	300	4080					
BKM0752	30	30.24	46	350	3720					
BKM0752	25	25.19	56	300	3500					
BKM0752	20	19.84	71	240	3230					
BKM0752	15	15.09	93	200	2950					
BKM0752	12.5	12.49	112	300	2770					
BKM0752	10	9.84	142	240	2550					
BKM0752	7.5	7.48	187	200	2330					

减速机选型表



# 减速机型号表 / GEAR UNIT SELECTION TABLES

BKM 090.. $n_1=1400r/min$						500Nm				
减速机型号 Gear units	i 公称 Nominal	i 实际 Actual	$n_2$ [r/min]	$M_{2max}$ [Nm]	$F_{r2}$ [N]	MS63	MS71	MS80	MS90	
3级/Stage										
BKM0903	300	295.18	4.7	500	8300					
BKM0903	250	240.89	5.8	500	8300					
BKM0903	200	200.66	7.0	480	8300					
BKM0903	150	151.20	9.3	500	8050					
BKM0903	125	125.95	11.1	480	7580					
BKM0903	100	99.22	14.1	380	7000					
BKM0903	75	75.45	18.6	300	6390					
BKM0903	60	62.43	22	480	6000					
BKM0903	50	49.18	28	380	5540					
2级/Stage										
BKM0902	60	59.04	24	500	5890					
BKM0902	50	48.18	29	500	5500					
BKM0902	40	40.13	35	480	5170					
BKM0902	30	30.24	46	500	4710					
BKM0902	25	25.19	56	480	4430					
BKM0902	20	19.84	71	380	4090					
BKM0902	15	15.09	93	300	3730					
BKM0902	12.5	12.49	112	480	3510					
BKM0902	10	9.84	142	380	3240					
BKM0902	7.5	7.48	187	300	2950					

减速机选型表



# 减速机型号表 / GEAR UNIT SELECTION TABLES

BKM 110.. $n_1=1400r/min$						750Nm				
减速机型号 Gear units	i 公称 Nominal	i 实际 Actual	$n_2$ [r/min]	$M_{2max}$ [Nm]	$F_{r2}$ [N]	MS63	MS71	MS80	MS90	
3级/Stage										
BKM1103	300	296.10	4.7	750	10000					
BKM1103	250	244.29	5.7	750	10000					
BKM1103	200	206.29	6.8	750	9920					
BKM1103	150	153.33	9.1	750	8980					
BKM1103	125	129.48	10.8	750	8490					
BKM1103	100	103.64	13.5	650	7880					
BKM1103	75	75.55	18.5	520	7090					
BKM1103	60	64.18	22	750	6720					
BKM1103	50	51.37	27	650	6240					
2级/Stage										
BKM1102	60	59.22	24	750	6540					
BKM1102	50	48.86	29	750	6130					
BKM1102	40	41.26	34	750	5800					
BKM1102	30	30.67	46	750	5250					
BKM1102	25	25.90	54	750	4960					
BKM1102	20	20.73	68	650	4610					
BKM1102	15	15.11	93	520	4150					
BKM1102	12.5	12.84	109	750	3930					
BKM1102	10	10.27	136	650	3650					
BKM1102	7.5	7.49	187	520	3280					

减速机选型表



SHUNDA TRANSMISSION

# 减速机型号表 / GEAR UNIT SELECTION TABLES

**BKM+ST伺服减速机组合表  $n_1=1500r/min$**



BKM	ST	7.5	10	12.5	15	20	25	30	40	50	60	75	100	125	150	200	250	300
050	100W																	
	200W	●	●	●														
	400W																	
	500W																	
	750W																	
	1000W																	
	1500W																	
063	200W	●	●	●	●	●	●	●										
	400W	●	●	●														
	500W																	
	750W																	
	1000W																	
	1500W																	
075	400W	●	●	●	●	●	●	●										
	500W	●	●	●														
	750W	●	●	●														
	1000W																	
	1500W																	
	2000W																	
	3000W																	
	4000W																	
090	400W	●	●	●	●	●	●	●										
	500W	●	●	●	●	●	●	●										
	750W	●	●	●														
	1000W	●	●	●														
	1500W																	
	2000W																	
	3000W																	
	4000W																	
110	750W	●	●	●	●	●	●	●										
	1000W	●	●	●	●													
	1500W	●	●	●														
	2000W																	
	3000W																	
	4000W																	
	5000W																	

减速机选型表

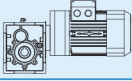

SHUNDA TRANSMISSION

# 性能参数 / PERFORMANCE PARAMETER

$P_{1n}$ [KW]	$n_2$ [r/min]	$M_{2max}$ [Nm]	$i$ 公称 Nominal	$i$ 实际 Actual	$F_{r2}$ [N]	K						
0.12	4.8	215	300	291.79	4100	0.6	BKM0503 MS6314	BKM0503 63B5	6314			
	5.7	180	250	244.29	4100	0.72						
	7.0	148	200	200.44	4100	0.88						
	9.5	108	150	146.67	4000	1.2						
	11.6	89	125	120.34	3770	1.5						
	13.9	74	100	101.04	3560	1.3						
	18.8	55	75	74.62	3220	1.5						
	22	46	60	62.36	3030	2.8						
	27	39	50	52.36	2860	2.6						
	24	44	60	58.36	2960	3.0				BKM0502 MS6314	BKM0502 63B5	6314
	29	37	50	48.86	2790	3.5						
	35	30	40	40.09	2610	4.3						
	48	22	30	29.33	2350	5.9						
	58	18.1	25	24.07	2200	7.2						
	69	15.2	20	20.21	2080	6.6						
	94	11.2	15	14.92	1880	7.1						
	112	9.4	12.5	12.47	1770	13.8						
	134	7.9	10	10.47	1670	12.7						
	181	5.8	7.5	7.73	1510	13.7						
	4.6	223	300	302.50	4800	0.9	BKM0633 MS6314	BKM0633 63B5	6314			
	5.7	179	250	243.57	4800	1.1						
	7.1	145	200	196.43	4800	1.2						
	9.2	112	150	151.56	4650	1.8						
	11.5	90	125	122.22	4330	2.0						
	13.8	75	100	101.27	4070	2.0						
	19.1	54	75	73.33	3650	2.0						
	22	47	60	63.33	3480	3.9						
	27	39	50	52.48	3270	3.9						
	23	46	60	60.50	3420	4.4				BKM0632 MS6314	BKM0632 63B5	6314
	29	37	50	48.71	3190	5.5						
	36	30	40	39.29	2970	6.1						
	46	23	30	30.31	2720	8.8						
	4.7	219	300	297.21	6500	1.6	BKM0753 MS6314	BKM0753 63B5	6314			
	5.8	177	250	240.89	6500	2.0						
	7.0	148	200	200.66	6500	2.0						
	9.3	111	150	151.20	6500	3.1						
11.1	93	125	125.95	5980	3.2							
14.1	73	100	99.22	5520	3.3							
18.6	56	75	75.45	5040	3.6							

性能参数



SHUNDA TRANSMISSION



## 性能参数 / PERFORMANCE PARAMETER

	$P_{1n}$ [KW]	$n_2$ [r/min]	$M_{2max}$ [Nm]	公称 Nominal	实际 Actual	$F_{r2}$ [N]	K			
0.12	4.7	217	300	295.18	8300	2.3	BKM0903 MS6314	BKM0903 63B5	6314	
	5.8	177	250	240.89	8300	2.8				
	7.0	148	200	200.66	8300	3.2				
	9.3	111	150	151.20	8050	4.5				
0.18	9.6	161	300	291.79	4000	0.81	BKM0503 MS6312	BKM0503 63B5	6312	
	11.5	135	250	244.29	3790	0.96				
	14.0	111	200	200.44	3550	1.2				
	19.1	81	150	146.67	3200	1.6				
	23	66	125	120.34	2990	2.0				
	28	56	100	101.04	2820	2.8				
	38	41	75	74.62	2550	1.9				
	45	34	60	62.36	2400	3.8				
	53	29	50	52.36	2270	3.5				
	0.18	11.6	133	125	120.34	3770	0.98	BKM0503 MS6324	BKM0503 63B5	6324
		13.9	112	100	101.04	3560	0.9			
		18.8	82	75	74.62	3220	0.97			
		22	69	60	62.36	3030	1.9			
		27	58	50	52.36	2860	1.7			
		24	66	60	58.36	2960	2.0			
	0.18	29	55	50	48.86	2790	2.1	BKM0502 MS6324	BKM0502 63B5	6324
		35	45	40	40.09	2610	2.9			
		48	33	30	29.33	2350	3.9			
		58	27	25	24.07	2200	4.8			
		69	23	20	20.21	2080	4.4			
		94	17.2	15	14.92	1880	4.7			
	0.18	14.4	107	60	62.36	3510	1.2	BKM0503 MS7116	BKM0503 71B5/B14	7116
		17.2	90	50	52.36	3310	1.1			
	0.18	15.4	103	60	58.36	3430	1.3	BKM0502 MS7116	BKM050271B5/B14	7116
		18.4	86	50	48.86	3240	1.5			
		22	70	40	40.09	3030	1.8			
		31	52	30	29.33	2730	2.5			
		37	42	25	24.07	2550	3.1			
45		36	20	20.21	2410	2.8				
60		26	15	14.92	2180	3.1				
72		22	12.5	12.47	2050	5.9				
86		18.4	10	10.47	1930	5.4				
116		13.6	7.5	7.73	1750	5.9				
9.3		167	300	302.50	4650	1.2	BKM0633 MS6312			
11.5	135	250	243.57	4330	1.5					
14.3	109	200	196.43	4030	1.7					
18.5	84	150	151.56	3690	2.4					
23	68	125	122.22	3440	2.7					

性能参数

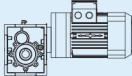

# 性能参数 / PERFORMANCE PARAMETER

$P_{1n}$ [KW]	$n_2$ [r/min]	$M_{2max}$ [Nm]	$i$ 公称 Nominal	$i$ 实际 Actual	$F_{r2}$ [N]	K			
0.18	28	56	100	101.27	3230	2.7	BKM0633 MS6312	BKM0633 63B5	6312
	38	41	75	73.33	2900	2.7			
	44	35	60	63.33	2760	5.1			
	53	29	50	52.48	2590	5.2			
	7.1	217	200	196.43	4800	0.83	BKM0633 MS6324	BKM0633 63B5	6324
	9.2	167	150	151.56	4650	1.2			
	11.5	1356	125	122.22	4330	1.3			
	13.8	112	100	101.27	4070	1.3			
	19.1	81	75	73.33	3650	1.4			
	22	70	60	63.33	3480	2.6			
	27	58	50	52.48	3270	2.6			
	23	68	60	60.50	3430	2.9	BKM0632 MS6324	BKM0632 63B5	6324
	29	55	50	48.71	3190	3.6			
	36	44	40	39.29	2970	4.1			
	7.4	210	125	122.22	4800	0.86	BKM0633 MS7116	BKM0633 71B5/B14	7116
	8.9	174	100	101.27	4720	0.86			
	12.3	126	75	73.33	4230	0.87			
	14.2	109	60	63.33	4030	1.7			
	17.1	90	50	52.48	3790	1.7			
	14.9	106	60	60.50	3970	1.9	BKM0632 MS7116	BKM0632 71B5/B14	7116
	18.5	86	50	48.71	3690	2.3			
	23	69	40	39.29	3440	2.6			
	30	53	30	30.31	3150	3.8			
	37	43	25	24.44	2930	4.2			
	44	36	20	20.25	2760	4.2			
	61	26	15	14.67	2470	4.3			
	9.4	164	300	297.21	6320	2.1	BKM0753 MS6312	BKM0753 63B5	6312
	11.6	133	250	240.89	5890	2.6			
	14.0	111	200	200.66	5540	2.7			
	18.5	84	150	151.20	5040	4.2			
	4.7	328	300	297.21	6500	1.1	BKM0753 MS6324	BKM0753 63B5	6324
	5.8	266	250	240.89	6500	1.3			
7.0	222	200	200.66	6500	1.4				
9.3	167	150	151.20	6500	2.1				
11.1	139	125	125.95	5980	2.2				
14.1	110	100	99.22	5520	2.2				
18.6	83	75	75.45	5040	2.4				
3.7	414	250	240.89	6500	0.85	BKM0753 MS7116			
4.5	345	200	200.66	6500	0.87				
6.0	260	150	151.20	6500	1.3				

性能参数



SHUNDA TRANSMISSION

# 性能参数 / PERFORMANCE PARAMETER

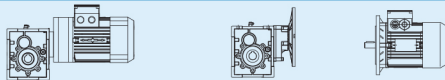
	$P_{1n}$ [KW]	$n_2$ [r/min]	$M_{2max}$ [Nm]	$i$		$F_{r2}$ [N]	K			
				公称 Nominal	实际 Actual					
0.18	7.1	217	125	125.95	6500	1.4	BKM0753 MS7116	BKM0753 71B5/B14	7116	
	9.1	171	100	99.22	6400	1.4				
	11.9	130	75	75.45	5840	1.5				
	14.4	107	60	62.43	5480	2.8				
	18.3	85	50	49.18	5060	2.8				
	15.1	107	60	59.44	5390	3.4	BKM0752 MS7116	BKM0752 71B5/B14	7116	
	18.7	85	50	48.18	5030	4.1				
	22	71	40	40.13	4730	4.3				
	9.5	163	300	295.18	7990	3.1	BKM0903 MS6312	BKM0903 63B5	6312	
	11.6	133	250	240.89	7470	3.8				
	14.0	111	200	200.66	7030	4.3				
	4.7	326	300	295.18	8300	1.5	BKM0903 MS6324	BKM0903 63B5	6324	
	5.8	266	250	240.89	8300	1.9				
	7.0	222	200	200.66	8300	2.2				
	9.3	167	150	151.20	8050	3.0				
	11.1	139	125	125.95	7580	3.4				
	14.1	110	100	99.22	7000	3.5				
	18.6	83	75	75.45	6390	3.6				
	3.0	507	300	295.18	8300	1.0	BKM0903 MS7116	BKM0903 71B5/B14	7116	
	3.7	414	250	240.89	8300	1.2				
	4.5	345	200	200.66	8300	1.4				
	6.0	260	150	151.20	8300	1.9				
	7.1	217	125	125.95	8300	2.2				
	9.1	171	100	99.22	8110	2.2				
	11.9	130	75	75.45	7400	2.3				
	14.4	107	60	62.43	6950	4.5				
	18.3	85	50	49.18	6420	4.5				
	3.0	520	300	296.10	10000	1.5	BKM1103 MS7116	BKM1103 71B5/B14	7116	
3.7	420	250	244.29	10000	1.8					
4.4	355	200	206.29	10000	2.1					
5.9	264	150	153.33	10000	2.8					
7.0	223	125	129.48	9840	3.4					
8.7	178	100	103.64	9130	3.6					
11.9	130	75	75.55	8220	4.0					
0.25	19.1	113	150	146.67	3200	1.2	BKM0503 MS6322	BKM0503 63B5	6322	
	23	92	125	120.34	2990	1.4				
	28	78	100	101.04	2820	1.3				
	38	57	75	74.62	2550	1.4				
	45	48	60	62.36	2400	2.7				
	53	40	50	52.36	2270	2.5				

性能参数

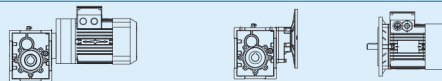

# 性能参数 / PERFORMANCE PARAMETER

	$P_{1n}$ [KW]	$n_2$ [r/min]	$M_{2max}$ [Nm]	$i$		$F_{r2}$ [N]	K			
				公称 Nominal	实际 Actual					
0.25	22	96	60	62.36	3030	1.4	BKM0503 MS6334	BKM0503 71B5/B14	7114	
	27	80	50	52.36	2860	1.2				
	24	92	60	58.36	2960	1.4	BKM0502 MS6334	BKM0502 71B5/B14	7114	
	29	77	50	48.86	2790	1.7				
	35	63	40	40.09	2610	2.1				
	48	46	30	29.33	2350	2.8				
	58	38	25	24.07	2200	3.4				
	69	32	20	20.21	2080	3.2				
	94	23	15	14.92	1880	3.4				
	15.4	142	60	58.36	3430	0.9	BKM0502 MS7126	BKM0502 71B5/B14	7126	
	18.4	119	50	48.86	3240	1.1				
	22	98	40	40.09	3030	1.3				
	31	72	30	29.33	2730	1.8				
	37	59	25	24.07	2550	2.2				
	45	49	20	20.21	2410	2.0				
	60	36	15	14.92	2180	2.2				
	72	30	12.5	12.47	2050	4.3				
	86	26	10	10.47	1930	3.9				
	116	19	7.5	7.73	1750	4.2				
	9.3	232	300	302.50	4650	0.86	BKM0633 MS6322	BKM063363B5	6322	
	11.5	187	250	243.57	4330	1.1				
	14.3	151	200	196.43	4030	1.2				
	18.5	116	150	151.56	3690	1.7				
	23	94	125	122.22	3440	1.9				
	28	78	100	101.27	3230	1.9				
	38	56	75	73.33	2900	2.0				
	44	49	60	63.33	2760	3.7				
	53	40	50	52.48	2590	3.7				
9.2	233	150	151.56	4650	0.86	BKM0633 MS6334	BKM0633 71B5/B14	7114		
11.5	188	125	122.22	4330	0.96					
13.8	155	100	101.27	4070	0.97					
19.1	113	75	73.33	3560	1.0					
22	97	60	63.33	3480	1.9					
27	81	50	52.48	3270	1.9					
23	95	60	60.50	3430	2.1				BKM0632 MS6334	BKM0632 71B5/B14
29	76	50	48.71	3190	2.6					
36	62	40	39.29	2970	2.9					
46	48	30	30.31	2720	4.2					
14.2	151	60	63.33	4030	1.2	BKM0753 MS7116	BKM0753 71B5/B14	7126		
17.1	125	50	52.48	3790	1.2					

性能参数



SHUNDA TRANSMISSION

## 性能参数 / PERFORMANCE PARAMETER

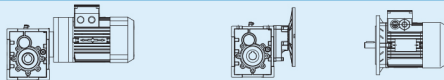

	$P_{1n}$ [KW]	$n_2$ [r/min]	$M_{2max}$ [Nm]	公称 Nominal	实际 Actual	$F_{r2}$ [N]	K			
0.25	14.9	148	60	60.50	3970	1.4	BKM0753 MS7116	BKM0753 71B5/B14	7116	
	18.5	119	50	48.71	3690	1.7				
	23	96	40	39.29	3440	1.9				
	30	74	30	30.31	3150	2.7				
	37	60	25	24.44	2930	3.0				
	44	49	20	20.25	2760	3.0				
	61	36	15	14.67	2470	3.1				
		9.4	228	300	297.21	6320	1.5	BKM0753 MS6322	BKM0753 63B5	6322
		11.6	185	250	240.89	5890	1.9			
		14.0	154	200	200.66	5540	1.9			
		18.5	116	150	151.20	5040	3.0			
		22	97	125	125.95	4750	3.1			
		28	76	100	99.22	4380	3.2			
		37	58	75	75.45	4000	3.5			
		5.8	370	250	240.89	6500	0.95	BKM0753 MS6334	BKM0753 71B5/B14	7114
		7.0	308	200	200.66	6500	1.0			
		9.3	232	150	151.20	6500	1.5			
		11.1	193	125	125.95	5980	1.6			
		14.1	152	100	99.22	5520	1.6			
		18.6	116	75	75.45	5040	1.7			
		22	96	60	62.43	4730	3.1			
		28	75	50	49.18	4370	3.2			
		24	93	60	59.44	4660	3.8	BKM0752 MS6334	BKM0752 71B5/B14	7114
		29	76	50	48.18	4340	4.6			
		6.0	361	150	151.20	6500	0.97	BKM0753 MS7126	BKM0753 71B5/B14	7126
		7.1	301	125	125.95	6500	1.0			
		9.1	237	100	99.22	6400	1.0			
		11.9	180	75	75.45	5840	1.1			
		14.4	149	60	62.43	5480	2.0			
		18.3	117	50	49.18	5060	2.0			
		15.1	145	60	59.44	5390	2.4	BKM0752 MS7126	BKM0752 71B5/B14	7126
		18.7	118	50	48.18	5030	3.0			
		22	98	40	40.13	4730	3.1			
		9.5	227	300	295.18	7990	2.2	BKM0903 MS6322	BKM0903 63B5	6322
		11.6	185	250	240.89	7470	2.7			
		14.0	154	200	200.66	7030	3.1			
	18.5	116	150	151.20	6390	4.3				
	4.7	453	300	295.18	8300	1.1	BKM0903 MS6334	BKM0903 71B5/B14	7114	
	5.8	370	250	240.89	8300	1.4				
	7.0	308	200	200.66	8300	1.6				

性能参数

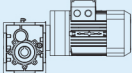

SHUNDA TRANSMISSION

# 性能参数 / PERFORMANCE PARAMETER

$P_{1n}$ [KW]	$n_2$ [r/min]	$M_{2max}$ [Nm]	$i$ 公称 Nominal	$i$ 实际 Actual	$F_{r2}$ [N]	K			
0.25	9.3	232	150	151.20	8050	2.2	BKM0903 MS6334	BKM0903 71B5/B14	7114
	11.1	193	125	125.95	7580	2.5			
	14.1	152	100	99.22	7000	2.5			
	18.6	116	75	75.45	6390	2.6			
	22	96	60	62.43	6000	5.0			
	28	75	50	49.18	5540	5.0			
	3.0	705	300	295.18	8300	0.71	BKM0903 MS7126	BKM0903 71B5/B14	7126
	3.7	575	250	240.89	8300	0.9			
	4.5	479	200	200.66	8300	1.0			
	6.0	361	150	151.20	8300	1.4			
	7.1	301	125	125.95	8300	1.6			
	9.1	237	100	99.22	8110	1.6			
	11.9	180	75	75.45	7400	1.7			
	14.4	149	60	62.43	6950	3.2			
	18.3	117	50	49.18	6420	3.2			
	15.2	144	60	59.04	6820	3.5	BKM0902 MS7126	BKM0902 71B5/B14	7126
	18.7	118	50	48.18	6370	4.3			
	4.7	454	300	296.10	10000	1.7	BKM1103 MS6334	BKM1103 71B5/B14	7114
	5.7	375	250	244.29	10000	2.0			
	6.8	317	200	206.29	9920	2.4			
9.1	235	150	153.33	8980	3.2				
10.8	199	125	129.48	8490	3.8				
13.5	159	100	103.64	7880	4.1				
3.0	707	300	296.10	10000	1.1	BKM1103 MS7126	BKM1103 71B5/B14	7126	
3.7	583	250	244.29	10000	1.3				
4.4	493	200	206.29	10000	1.5				
5.9	366	150	153.33	10000	2.0				
7.0	309	125	129.48	9840	2.4				
8.7	247	100	103.64	9130	2.6				
11.9	180	75	75.55	8220	2.9				
0.37	23	137	125	120.34	2990				0.95
	28	115	100	101.04	2820	0.87			
	38	85	75	74.62	2550	0.94			
	45	71	60	62.36	2400	1.8			
	53	59	50	52.36	2270	1.7			
	24	136	60	58.36	2960	0.96	BKM0502 MS7124	BKM0502 71B5/B14	7124
	29	113	50	48.86	2790	1.1			
	35	93	40	40.09	2610	1.4			
	48	68	30	29.33	2350	1.9			
	58	56	25	24.07	2200	2.3			

性能参数



SHUNDA TRANSMISSION

## 性能参数 / PERFORMANCE PARAMETER

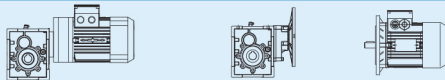
	$P_{1n}$ [KW]	$n_2$ [r/min]	$M_{2max}$ [Nm]	公称 Nominal	实际 Actual	$F_{r2}$ [N]	K			
0.37	69	47	20	20.21	2080	2.1	BKM0502 MS7124	BKM0502 71B5/B14	7124	
	94	35	15	14.92	1880	2.3				
	112	29	12.5	12.47	1770	4.5				
	134	24	10	10.47	1670	4.1				
	181	17.9	7.5	7.73	1510	4.5				
	22	145	40	40.09	3030	0.9	BKM0502 MS8016	BKM0502 63B5	6322	
	31	106	30	29.33	2730	1.2				
	37	87	25	24.07	2550	1.5				
	45	73	20	20.21	2410	1.4				
	60	54	15	14.92	2180	1.5				
	72	45	12.5	12.47	2050	2.9				
	86	38	10	10.47	1930	2.6				
	116	28	7.5	7.73	1750	2.9				
	18.5	172	150	151.56	3690	1.2	BKM0633 MS6332	BKM0633 71B5/B14	7112	
	23	139	125	122.22	3440	1.3				
	28	115	100	101.27	3230	1.3				
	38	83	75	73.33	2900	1.3				
	44	72	60	63.33	2760	2.5				
	53	60	50	52.48	2590	2.5				
	22	144	60	63.33	3480	1.3	BKM0633 MS7124	BKM0633 71B5/B14	7124	
	27	119	50	52.48	3270	1.3				
	23	140	60	60.50	3430	1.4	BKM0632 MS7124	BKM0632 71B5/B14	7124	
	29	113	50	48.71	3190	1.8				
	36	91	40	39.29	2970	2.0				
	46	70	30	30.31	2720	2.8				
	57	57	25	24.44	2530	3.2				
	69	47	20	20.25	2380	3.2				
	95	34	15	14.67	2130	3.2				
14.9	219	60	60.50	3970	0.92	BKM0632 MS8016	BKM0632 80B5/B14	8016		
18.5	176	50	48.71	3690	1.1					
23	142	40	39.29	3440	1.3					
30	109	30	30.31	3150	1.8					
37	88	25	24.44	2930	2.0					
44	73	20	20.25	2760	2.1					
61	53	15	14.67	2470	2.1					
71	46	12.5	12.67	2360	3.9					
86	38	10	10.50	2210	4.0					
118	27	7.5	7.60	1990	4.0					
9.4	338	300	297.21	6320	1.0	BKM0753 MS6332	BKM0753 71B5/B14	7112		
11.6	274	250	240.89	5890	1.3					

性能参数



SHUNDA TRANSMISSION

# 性能参数 / PERFORMANCE PARAMETER

	$P_{1n}$ [KW]	$n_2$ [r/min]	$M_{2max}$ [Nm]	$i$	$i$	$F_{r2}$ [N]	K			
				公称 Nominal	实际 Actual			BKM0753 MS6332	BKM0753 71B5/B14	7112
0.37	14.0	228	200	200.66	5540	1.3	BKM0753 MS6332	BKM0753 71B5/B14	7112	
	18.5	172	150	151.20	5040	2.0				
	22	143	125	125.95	4750	2.1				
	28	113	100	99.22	4380	2.1				
	37	86	75	75.45	4000	2.3				
	45	71	60	62.43	3750	4.2				
	57	56	50	49.18	3470	4.3				
	9.3	343	150	151.20	6500	1.0	BKM0753 MS7124	BKM0753 71B5/B14	7124	
	11.1	286	125	125.95	5980	1.0				
	14.1	225	100	99.22	5520	1.1				
	18.6	171	75	75.45	5040	1.2				
	22	142	60	62.43	4730	2.1				
	28	112	50	49.18	4370	2.1				
	24	138	60	59.44	4660	2.5	BKM0752 MS7124	BKM0752 71B5/B14	7124	
	29	112	50	48.18	4340	3.1				
	35	93	40	40.13	4080	3.2				
	14.4	221	60	62.43	5480	1.4	BKM0753 MS8016	BKM0753 80B5/B14	8016	
	18.3	174	50	49.18	5060	1.4				
	15.1	215	60	59.44	5390	1.6	BKM0752 MS8016	BKM0752 80B5/B14	8016	
	18.7	174	50	48.18	5030	2.0				
	22	145	40	40.13	4730	2.1				
	30	109	30	30.24	4310	3.2				
	36	91	25	25.19	4050	3.3				
	45	72	20	19.84	3740	3.3				
	60	55	15	15.09	3410	3.7				
	9.5	335	300	295.18	7990	1.5	BKM0903 MS6332	BKM0903 71B5/B14	7112	
	11.6	274	250	240.89	7470	1.8				
	14.0	228	200	200.66	7030	2.1				
	18.5	172	150	151.20	6390	2.9				
	22	143	125	125.95	6010	3.4				
28	113	100	99.22	5550	3.4					
37	86	75	75.45	5070	3.5					
4.7	671	300	295.18	8300	0.75	BKM0903 MS7124	BKM0903 71B5/B14	7124		
5.8	547	250	240.89	8300	0.91					
7.0	456	200	200.66	8300	1.1					
9.3	343	150	151.20	8050	1.5					
11.1	286	125	125.95	7580	1.7					
14.1	225	100	99.22	7000	1.7					
18.6	171	75	75.45	6390	1.8					
22	142	60	62.43	6000	3.4					

性能参数



SHUNDA TRANSMISSION

## 性能参数 / PERFORMANCE PARAMETER

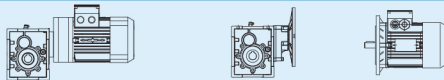

	$P_{1n}$ [KW]	$n_2$ [r/min]	$M_{2max}$ [Nm]	公称 Nominal	实际 Actual	$F_{r2}$ [N]	K			
								BKM0903 MS7124	BKM0903 71B5/B14	7124
0.37	28	112	50	49.18	5540	3.4	BKM0902 MS7124	BKM0902 71B5/B14	7124	
	24	137	60	59.04	5890	3.6				
	29	112	50	48.18	5500	4.5				
	6.0	534	150	151.20	8300	0.94	BKM0903 MS8016	BKM0903 80B5/B14	8016	
	7.1	445	125	125.95	8300	1.1				
	9.1	351	100	99.22	8110	1.1				
	11.9	267	75	75.45	7400	1.1				
	14.4	221	60	62.43	6950	2.2				
	18.3	174	50	49.18	6420	2.2				
	15.2	213	60	59.04	6820	2.3	BKM0902 MS8016	BKM0902 80B5/B14	8016	
	18.7	174	50	48.18	6370	2.9				
	22	145	40	40.13	6000	3.3				
	9.5	336	300	296.10	8880	2.2	BKM1103 MS7124	BKM1103 71B5/B14	7112	
	11.5	277	250	244.29	8330	2.7				
	13.6	234	200	206.29	7870	3.2				
	18.3	174	150	153.33	7130	4.3				
	4.7	673	300	296.10	10000	1.1	BKM1103 MS7124	BKM1103 71B5/B14	7124	
	5.7	555	250	244.29	10000	1.4				
	6.8	469	200	206.29	9920	1.6				
	9.1	348	150	153.33	8980	2.2				
	10.8	294	125	129.48	8490	2.5				
	13.5	235	100	103.64	7880	2.8				
	18.5	172	75	75.55	7090	3.0				
	4.4	729	200	206.29	10000	1.0	BKM1103 MS8016	BKM1103 80B5/B14	8016	
	5.9	542	150	153.33	10000	1.4				
	7.0	458	125	129.48	9840	1.6				
	8.7	366	100	103.64	9130	1.8				
	11.9	267	75	75.55	8220	1.9				
14.0	227	60	64.18	7780	3.3					
17.5	182	50	51.37	7230	3.6					
15.2	214	65	59.22	7580	3.5	BKM1102 MS8016	BKM1102 80B5/B14	8016		
18.4	176	50	48.86	7110	4.2					
0.55	45	105	65	62.36	2400	1.2	BKM0503 MS7112	BKM0503 71B5/B14	7112	
	53	88	50	52.36	2270	1.1				
	35	138	40	40.09	2610	0.94	BKM0502 MS8014	BKM0502 80B5/B14	8014	
	48	101	30	29.33	2350	1.3				
	58	83	25	24.07	2200	1.6				
	69	70	20	20.21	2080	1.4				
	94	51	15	14.92	1880	1.6				
112	43	12.5	12.47	1770	3.0					

性能参数

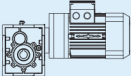

SHUNDA TRANSMISSION

## 性能参数 / PERFORMANCE PARAMETER

P <sub>1n</sub> [KW]	n <sub>2</sub> [r/min]	M <sub>2max</sub> [Nm]	i	i	F <sub>r2</sub> [N]	K						
			公称 Nominal	实际 Actual								
0.55	134	36	10	10.47	1670	2.8	BKM0502 MS8014	BKM0502 80B5/B14	8014			
	181	27	7.5	7.73	1510	3.0						
	37	129	25	24.07	2550	1.0	BKM0502 MS8026	BKM0502 80B5/B14	8026			
	45	109	20	20.21	2410	0.92						
	60	80	15	14.92	2180	1.0						
	72	67	12.5	12.47	2050	1.9						
	86	56	10	10.47	1930	1.8						
	116	42	7.5	7.73	1750	1.9						
	23	206	125	122.22	3440	0.87	BKM0633 MS7122	BKM0633 71B5/B14	7122			
	28	171	100	101.27	3230	0.88						
	38	124	75	73.33	2900	0.9						
	44	107	60	63.33	2760	1.7						
	53	89	50	52.48	2590	1.7						
	23	209	60	60.50	3430	0.96	BKM0632 MS8014	BKM0632 80B5/B14	8014			
	29	168	50	48.71	3190	1.2						
	36	136	40	39.29	2970	1.3						
	46	105	30	30.31	2720	1.9						
	57	84	25	24.44	2530	2.1						
	69	70	20	20.25	2380	2.1						
	95	51	15	14.67	2130	2.2						
	110	44	12.5	12.67	2030	4.1						
	133	36	10	10.50	1910	4.1						
	184	26	7.5	7.60	1710	4.2						
	23	216	40	39.29	3440	0.85	BKM0632 MS8026	BKM0632 80B5/B14	8026			
	30	163	30	30.31	3150	1.2						
	37	131	25	24.44	2930	1.4						
	44	109	20	20.25	2760	1.4						
	61	79	15	14.67	2470	4.4						
	71	68	12.54	12.67	2360	2.6						
	86	56	10	10.50	2210	2.7						
118	41	7.5	7.60	1990	2.7							
11.6	407	250	240.89	5890	0.86	BKM0753 MS7122	BKM0753 71B5/B14	7122				
14.0	339	200	200.66	5540	0.9							
18.5	255	150	151.20	5040	1.4							
22	213	125	125.95	4750	1.4							
28	168	100	99.22	4380	1.4							
37	127	75	75.45	4000	1.6							
45	105	60	62.43	3750	2.8							
57	83	50	49.18	3470	2.9							
18.6	255	75	75.45	5040	0.8						BKM0753 MS8014	BKM0753 80B5/B14

性能参数



SHUNDA TRANSMISSION

# 性能参数 / PERFORMANCE PARAMETER

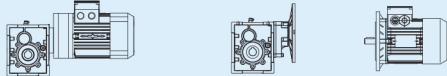

P <sub>1n</sub> [KW]	n <sub>2</sub> [r/min]	M <sub>2max</sub> [Nm]	i		F <sub>r2</sub> [N]	K			
			公称 Nominal	实际 Actual					
0.55	22	211	60	62.43	4730	1.4	BKM0753 MS8014	BKM0753 80B5/B14	8014
	28	166	50	49.18	4370	1.4			
	24	205	60	59.44	4660	1.7	BKM0752 MS8014	BKM0752 80B5/B14	8014
	29	166	50	48.18	4340	2.1			
	35	139	40	40.13	4080	2.2			
	46	104	30	30.24	3720	3.4			
	56	87	25	25.19	3500	3.5			
	71	68	20	19.84	3230	3.5			
	93	52	15	15.09	2950	3.8			
	14.4	328	60	62.43	5480	0.91	BKM0753 MS8026	BKM0753 80B5/B14	8026
	18.3	258	50	49.18	5060	0.93			
	15.1	319	60	59.44	5390	1.1	BKM0752 MS8026	BKM0752 80B5/B14	8026
	18.7	259	50	48.18	5030	1.4			
	22	215	40	40.13	4730	1.4			
	30	162	30	30.24	4310	2.2			
	36	135	25	25.19	4050	2.2			
	45	107	20	19.84	3740	2.3			
	60	81	15	15.09	3410	2.5			
	9.5	498	300	295.18	7990	1.0	BKM0903 MS7122	BKM0903 71B5/B14	7122
	11.6	407	250	240.89	7470	1.2			
	14.0	339	200	200.66	7030	1.4			
	18.5	255	150	151.20	6390	2.0			
	22	213	125	125.95	6010	2.3			
	28	168	100	99.22	5550	2.3			
	37	127	75	75.45	5070	2.4			
	45	105	60	62.43	4760	4.6			
	57	83	50	49.18	4390	4.6			
	9.3	511	150	151.20	8050	1.0	BKM0903 MS8014	BKM0903 80B5/B14	8014
	11.1	425	125	125.95	7580	1.1			
	14.1	335	100	99.22	7000	1.1			
18.6	255	75	75.45	6390	1.2				
22	211	60	62.43	6000	2.3				
28	166	50	49.18	5540	2.3				
24	204	60	59.04	5890	2.5	BKM0902 MS8014	BKM0902 80B5/B14	8014	
29	166	50	48.18	5500	3.0				
35	139	40	40.13	5170	3.5				
46	104	30	30.24	4710	4.8				
14.4	328	60	62.43	6950	1.5	BKM0903 MS8026	BKM0903 80B5/B14	8026	
18.3	258	50	49.18	6420	1.5				
15.2	317	60	59.04	6820	1.5	BKM0902 MS8026	BKM0902 80B5/B14	8026	

性能参数

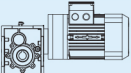

SHUNDA TRANSMISSION

## 性能参数 / PERFORMANCE PARAMETER

$P_{1n}$ [KW]	$n_2$ [r/min]	$M_{2max}$ [Nm]	$i$ 公称 Nominal	$i$ 实际 Actual	$F_{r2}$ [N]	K			
0.55	18.7	259	50	48.18	6370	1.9	BKM0902 MS8026	BKM0902 80B5/B14	8026
	22	215	40	40.13	6000	2.2			
	30	162	30	30.24	5460	3.1			
	36	135	25	25.19	5130	3.5			
	45	107	20	19.84	4740	3.6			
	60	81	15	15.09	4330	3.7			
	9.5	500	300	296.10	8880	1.5	BKM1103 MS7122	BKM1103 71B5/B14	7122
	11.5	412	250	244.29	8330	1.8			
	13.6	348	200	206.29	7870	2.2			
	18.3	259	150	153.33	7130	2.9			
	22	219	125	129.48	6740	3.4			
	27	175	100	103.64	6260	3.7			
	37	128	75	75.55	5630	4.1			
	5.7	825	250	244.29	10000	0.91	BKM1103 MS8014	BKM1103 80B5/B14	8014
	6.8	697	200	206.29	9920	1.1			
	9.1	518	150	153.33	8980	1.4			
	10.8	437	125	129.48	8490	1.7			
	13.5	350	100	103.64	7880	1.9			
	18.5	255	75	75.55	7090	2.0			
	22	217	60	64.18	6720	3.5			
	27	173	50	51.37	6240	3.7			
	24	204	60	59.22	6540	3.7	BKM1102 MS8014	BKM1102 80B5/B14	8014
	29	169	50	48.86	6130	4.4			
	5.9	805	150	153.33	10000	0.93	BKM1103 MS8026	BKM1103 80B5/B14	8026
	7.0	680	125	129.48	9840	1.1			
	8.7	544	100	103.64	9130	1.2			
	11.9	397	75	75.55	8220	1.3			
	14.0	337	60	64.18	7780	2.2			
17.5	270	50	51.37	7230	2.4				
15.2	318	60	59.22	7580	2.4	BKM1102 MS8026	BKM1102 80B5/B14	8026	
18.4	262	50	48.86	7110	2.9				
22	222	40	41.26	6720	3.4				
29	165	30	30.67	6090	4.6				
0.75	48	138	30	29.33	2350	0.94	BKM0502 MS8024	BKM0502 80B5/B14	8024
	58	113	25	24.07	2200	1.1			
	69	95	20	20.21	2080	1.1			
	94	70	15	14.92	1880	1.1			
	112	59	12.5	12.47	1770	2.2			
	134	49	10	10.47	1670	2.0			
	181	36	7.5	7.73	1510	2.2			

性能参数



SHUNDA TRANSMISSION

# 性能参数 / PERFORMANCE PARAMETER

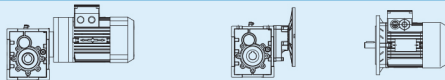
性能参数	$P_{1n}$ [KW]	$n_2$ [r/min]	$M_{2max}$ [Nm]	公称 Nominal	实际 Actual	$F_{r2}$ [N]	K		
0.75	72	91	91	12.47	2050	1.4	BKM0502 MS90S6	BKM0502 90B5/B14	90S6
	86	77	77	10.47	1930	1.3			
	116	57	57	7.73	1750	1.4			
	44	146	146	63.33	2760	1.2	BKM0633 MS8012	BKM0633 80B5/B14	8012
	53	121	121	52.48	2590	1.2			
	29	229	229	48.71	3190	0.87	BKM0632 MS8024	BKM0632 80B5/B14	8024
	36	185	185	39.29	2970	0.97			
	46	143	143	30.31	2720	1.4			
	57	115	115	24.44	2530	1.6			
	69	95	95	20.25	2380	1.6			
	95	69	69	14.67	2130	1.6			
	110	60	60	12.67	2030	3.0			
	133	49	49	10.50	1910	3.0			
	184	36	36	7.60	1710	3.1			
	30	222	222	30.31	3150	0.9	BKM0632 MS90S6	BKM0632 90B5/B14	90S6
	37	179	179	24.44	2930	1.0			
	44	148	148	20.25	2760	1.0			
	61	107	107	14.67	2470	1.0			
	71	93	93	12.67	2360	1.9			
	86	77	77	10.50	2210	2.0			
	118	56	56	7.60	1990	2.0			
	18.5	348	348	151.20	5040	1.0	BKM0753 MS8012	BKM0753 80B5/B14	8012
	22	290	290	125.95	4750	1.0			
	28	228	228	99.22	4380	1.1			
	37	174	174	75.45	4000	1.2			
	45	144	144	62.43	3750	2.1			
	57	113	113	49.18	3470	2.1			
	22	287	287	62.43	4730	1.0	BKM0753 MS8024	BKM0753 80B5/B14	8024
	28	226	226	49.18	4370	1.1			
	24	280	280	59.44	4660	1.3	BKM0752 MS8024	BKM0752 80B5/B14	8024
29	227	227	48.18	4340	1.5				
35	189	189	40.13	4080	1.6				
46	142	142	30.24	3720	2.5				
56	119	119	25.19	3500	2.5				
71	93	93	19.84	3230	2.6				
93	71	71	15.09	2950	2.8				
18.7	353	353	48.18	5030	1.0	BKM0752 MS90S6	BKM0752 90B5/B14	90S6	
22	294	294	40.13	4730	1.0				
30	221	221	30.24	4310	1.6				
36	184	184	25.19	5050	1.6				



SHUNDA TRANSMISSION

## 性能参数 / PERFORMANCE PARAMETER

$P_{1n}$ [KW]	$n_2$ [r/min]	$M_{2max}$ [Nm]	$i$		$F_{r2}$ [N]	K				
			公称 Nominal	实际 Actual						
0.75	45	145	20	19.84	3740	1.7	BKM0752 MS90S6	BKM0752 90B5/B14	90S6	性能参数
	60	110	15	15.09	3410	1.8				
	72	91	12.5	12.49	3210	3.3				
	91	72	10	9.84	2960	3.3				
	120	55	7.5	7.48	2700	3.7				
	11.6	555	250	240.89	7470	0.9	BKM0903 MS8012	BKM0903 80B5/B14	8012	
	14.0	462	200	200.66	7030	1.0				
	18.5	348	150	151.20	6390	1.4				
	22	290	125	125.95	6010	1.7				
	28	228	100	99.22	5550	1.7				
	37	174	75	75.45	5070	1.7				
	45	144	60	62.43	4760	3.3				
	57	113	50	49.18	4390	3.4				
	11.1	580	125	125.95	7580	0.83	BKM0903 MS8024	BKM0903 80B5/B14	8024	
	14.1	457	100	99.22	7000	0.83				
	18.6	247	75	75.45	6390	0.86				
	22	287	60	62.43	6000	1.7				
	28	226	50	49.18	5540	1.7				
	24	278	60	59.04	5890	1.8	BKM0902 MS8024	BKM0902 80B5/B14	8024	
	29	227	50	48.18	5500	2.2				
	35	189	40	40.13	5170	2.5				
	46	142	30	30.24	4710	3.5				
	56	119	25	25.19	4430	4.0				
	71	93	20	19.84	4090	4.1				
	93	71	15	15.09	3730	4.2				
	14.4	447	60	62.43	6950	1.1	BKM0903 MS90S6	BKM0903 90B5/B14	90S6	
	18.3	352	50	49.18	6420	1.1				
	15.2	432	60	59.04	6820	1.2	BKM0902 MS90S6	BKM0902 90B5/B14	90S6	
	18.7	353	50	48.18	6370	1.4				
	22	294	40	40.13	6000	1.6				
	30	221	30	30.24	5460	2.3				
	36	184	25	25.19	5130	2.6				
	45	145	20	19.84	4740	2.6				
	60	110	15	15.09	4330	2.7				
	9.5	682	300	296.10	8880	1.1				
	11.5	562	250	244.29	8330	1.3				
13.6	475	200	206.29	7870	1.6					
18.3	353	150	153.33	7130	2.1					
22	298	125	129.48	6740	2.5					
27	239	100	103.64	6260	2.7					



SHUNDA TRANSMISSION

# 性能参数 / PERFORMANCE PARAMETER

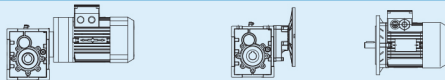
	$P_{1n}$ [KW]	$n_2$ [r/min]	$M_{2max}$ [Nm]	i 公称 Nominal	i 实际 Actual	$F_{r2}$ [N]	K			
0.75	37	174	75	75.55	5630	3.0		BKM1103 MS8012	BKM1103 80B5/B14	8012
	9.1	706	150	153.33	8980	1.1	BKM1103 MS8024	BKM1103 80B5/B14	8024	
	10.8	596	125	129.48	8490	1.3				
	13.5	477	100	103.64	7880	1.4				
	18.5	348	75	75.55	7090	1.5				
	22	296	60	64.18	6720	2.5				
	27	237	50	51.37	6240	2.7				
	24	279	60	59.22	6540	2.7	BKM1102 MS8024	BKM1102 80B5/B14	8024	
	29	230	50	48.86	6130	3.3				
	34	194	40	41.26	5800	3.9				
	8.7	742	100	103.64	9130	0.88	BKM1103 MS90S6	BKM1103 90B5/B14	90S6	
	11.9	541	75	75.55	8220	0.96				
	14.0	460	60	64.18	7780	1.6				
	17.5	368	50	51.37	7230	1.8				
15.2	434	60	59.22	7580	1.7					
18.4	358	50	48.86	7110	2.1	BKM1102 MS90S6	BKM1102 90B5/B14	90S6		
22	302	40	41.26	6720	2.5					
29	225	30	30.67	6090	3.3					
35	190	25	25.90	5750	4.0					
43	152	20	20.73	5340	4.3					
112	86	12.5	12.47	1770	1.5				BKM0502 MS90S4	BKM0502 90B5/B14
134	72	10	10.47	1670	1.4					
181	53	7.5	7.73	1510	1.5					
72	134	30	12.47	2050	0.97	BKM0502 MS90L6	BKM0502 90B5/B14	90L6		
86	112	25	10.47	1930	0.89					
116	83	20	7.73	1750	0.96					
46	209	15	30.31	2720	0.96	BKM0632 MS90S4	BKM0632 90B5/B14	90S4		
57	169	12.5	24.44	2530	1.1					
69	140	10	20.25	2380	1.1					
95	101	7.5	14.67	2130	1.1					
110	87	12.5	12.67	2030	2.1					
133	72	10	10.50	1910	2.1					
184	52	7.5	7.60	1710	2.1					
71	136	12.5	12.67	2360	1.3	BKM0632 MS90L6	BKM0632 90B5/B14	90L6		
86	113	10	10.50	2210	1.3					
118	82	7.5	7.60	1990	1.3					
45	211	60	62.43	3750	1.4	BKM0753 MS8022	BKM0753 80B5/B14	8022		
57	166	50	49.18	3470	1.4					
24	410	60	59.44	4660	0.85	BKM0752 MS90S4	BKM0752 90B5/B14	90S4		
29	333	50	48.18	4340	1.1					

性能参数



SHUNDA TRANSMISSION

## 性能参数 / PERFORMANCE PARAMETER

P <sub>1n</sub> [KW]	n <sub>2</sub> [r/min]	M <sub>2max</sub> [Nm]	i		F <sub>r2</sub> [N]	K			
			公称 Nominal	实际 Actual					
1.1	35	277	40	40.13	4080	1.1	BKM0752 MS90S4	BKM0752 90B5/B14	90S4
	46	209	30	30.24	3720	1.7			
	56	174	25	25.19	3500	1.7			
	71	137	20	19.84	3230	1.8			
	93	104	15	15.09	2950	1.9			
	112	86	12.5	12.49	2770	3.5			
	142	68	10	9.84	2550	3.5			
	187	52	7.5	7.48	2330	3.9			
	30	325	30	30.24	4310	1.1	BKM0752 MS90L6	BKM0752 90B5/B14	90L6
	36	271	25	25.19	4050	1.1			
	45	213	10	19.84	3740	1.1			
	60	162	15	15.09	3410	1.2			
	72	134	12.5	12.49	3210	2.2			
	91	106	10	9.84	2960	2.3			
	120	80	7.5	7.48	2700	2.5			
	18.5	511	150	151.20	6390	1.0	BKM0903 MS8022	BKM0903 80B5/B14	8022
	22	425	125	125.95	6010	1.1			
	28	335	100	99.22	5550	1.1			
	37	255	75	75.45	5070	1.2			
	45	211	60	62.43	4760	2.3			
	57	166	50	49.18	4390	2.3			
	22	422	60	62.43	6000	1.1	BKM0903 MS90S4	BKM0903 90B5/B14	90S4
	28	332	50	49.18	5540	1.1			
	24	408	60	59.04	5890	1.2	BKM0902 MS90S4	BKM0902 90B5/B14	90S4
	29	333	50	48.18	5500	1.5			
	35	277	40	40.13	5170	1.7			
	46	209	30	30.24	4710	2.4			
	56	174	25	25.19	4430	2.8			
	71	137	20	19.84	4090	2.8			
	93	104	15	15.09	3730	2.9			
	15.2	634	60	59.04	6820	0.8	BKM0902 MS90L6	BKM0902 90B5/B14	90L6
	18.7	517	50	48.18	6370	0.97			
	22	431	40	40.13	6000	1.1			
	30	325	30	30.24	5460	1.5			
	36	271	25	25.19	5130	1.8			
	45	213	20	19.84	4740	1.8			
60	162	15	15.09	4330	1.9				
72	134	12.5	12.49	4060	3.6				
91	106	10	9.84	3750	3.6				
120	80	7.5	7.48	3420	3.7				

性能参数



SHUNDA TRANSMISSION

## 性能参数 / PERFORMANCE PARAMETER

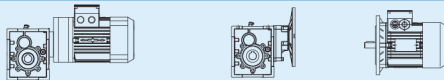
	$P_{1n}$ [KW]	$n_2$ [r/min]	$M_{2max}$ [Nm]	i 公称 Nominal	i 实际 Actual	$F_{r2}$ [N]	K			
1.1	11.5	825	250	244.29	8330	0.91	BKM1103 MS8022	BKM1103 80B5/B14	8022	
	13.6	697	200	206.29	7870	1.1				
	18.3	518	150	153.33	7130	1.4				
	22	437	125	129.48	6740	1.7				
	27	350	100	103.64	6260	1.9				
	37	255	75	75.55	5630	2.0				
	44	217	60	64.18	5330	3.5				
	55	173	50	51.37	4950	3.7				
	10.8	874	125	129.48	8490	0.86	BKM1103 MS90S4	BKM1103 90B5/B14	90S4	
	13.5	700	100	103.64	7880	0.93				
	18.5	510	75	75.55	7090	1.0				
	22	433	60	64.18	6720	1.7				
	27	347	50	51.37	6240	1.9				
	24	409	60	59.22	6540	1.8	BKM1102 MS90S4	BKM1102 90B5/B14	90S4	
	29	337	50	48.86	6130	2.2				
	34	285	40	41.26	5800	2.6				
	46	212	30	30.67	5250	3.5				
	54	179	25	25.90	4960	4.2				
	68	143	20	20.73	4610	4.5				
	14.0	674	60	64.18	7780	1.1	BKM1103 MS90L6	BKM1103 90B5/B14	90L6	
	17.5	540	50	51.37	7230	1.2				
	15.2	636	60	59.22	7580	1.2	BKM1102 MS90L6	BKM1102 90B5/B14	90L6	
	18.4	525	50	48.86	7110	1.4				
	22	443	40	41.26	6720	1.7				
29	329	30	30.67	6090	2.3					
35	278	25	25.90	5750	2.7					
43	223	20	20.73	5340	2.9					
60	162	15	15.11	4810	3.2					
1.5	112	117	12.5	12.47	1770	1.1				BKM0502 MS90L4
	134	99	10	10.47	1670	1.0				
	181	73	7.5	7.73	1510	1.1				
	57	230	25	24.44	2530	0.8	BKM0632 MS90L4	BKM0632 90B5/B14	90L4	
	69	191	20	20.25	2380	0.8				
	95	138	15	14.67	2130	0.8				
	110	119	12.5	12.67	2030	1.5				
	133	99	10	10.50	1910	1.5				
	184	72	7.5	7.60	1710	1.5				
	45	287	60	62.43	3750	10	BKM0753 MS90S2	BKM0753 90B5/B14	90S2	
	57	226	50	49.18	3470	11				
	29	454	50	48.18	4340	0.77	BKM0752 MS90L4	BKM0752 90B5/B14	90L4	

性能参数



SHUNDA TRANSMISSION

## 性能参数 / PERFORMANCE PARAMETER

$P_{1n}$ [KW]	$n_2$ [r/min]	$M_{2max}$ [Nm]	$i$		$F_{r2}$ [N]	K				
			公称 Nominal	实际 Actual						
1.5	35	378	40	40.13	4080	0.79	BKM0752 MS90L4	BKM0752 90B5/B14	90L4	
	46	285	30	30.24	3720	1.2				
	56	237	25	25.19	3500	1.3				
	71	187	20	19.84	3230	1.3				
	93	142	15	15.09	2950	1.4				
	112	118	12.5	12.49	2770	2.6				
	142	93	10	9.84	2550	2.6				
	187	70	7.5	7.48	2330	2.8				
	45	291	20	19.84	3740	0.83				
	60	221	15	15.09	3410	0.91				
	72	183	12.5	12.49	3210	1.6				
	91	144	10	9.84	2960	1.7				
	120	110	7.5	7.48	2700	1.8				
	22	580	125	125.95	6010	0.83	BKM0903 MS90S2	BKM0903 90B5/B14	90S2	
	28	457	100	99.22	5550	0.85				
	37	347	75	75.45	5070	0.86				
	45	287	60	62.43	4760	1.7				
	57	226	50	49.18	4390	1.7				
	24	556	60	59.04	5890	0.9	BKM0902 MS90L4	BKM0902 90B5/B14	90L4	
	29	454	50	48.18	5500	1.1				
	35	378	40	40.13	5170	1.3				
	46	285	30	30.24	4710	1.8				
	56	237	25	25.19	4430	2.0				
	71	187	20	19.84	4090	2.0				
	93	142	15	15.09	3730	2.1				
	112	118	12.5	12.49	3510	4.1				
	142	93	10	9.84	3240	4.1				
	187	70	7.5	7.48	2950	4.3				
	30	443	30	30.24	5460	1.1	BKM0902 MS100L6	BKM0902 100B5/B14	100L6	
	36	369	25	25.19	5130	1.3				
	45	291	20	19.84	4740	1.3				
	60	221	15	15.09	4330	1.4				
	72	183	12.5	12.49	4060	2.6				
	91	144	10	9.84	3750	2.6				
	120	110	7.5	7.48	3420	2.7				
	18.3	706	150	153.33	7130	1.1	BKM1103 MS90S2	BKM1103 90B5/B14	90S2	
22	596	125	129.48	6740	1.3					
27	477	100	103.64	6260	1.4					
37	348	75	75.55	5630	1.5					
44	296	60	64.18	5330	2.5					

性能参数



SHUNDA TRANSMISSION

## 性能参数 / PERFORMANCE PARAMETER

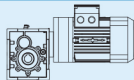
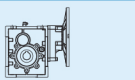
	$P_{1n}$ [KW]	$n_2$ [r/min]	$M_{2max}$ [Nm]	i 公称 Nominal	i 实际 Actual	$F_{r2}$ [N]	K				
1.5	55	237	50	51.37	4950	2.7	BKM1103 MS90S2	BKM1103 90B5/B14	90S2		
	22	591	60	64.18	6720	1.3	BKM1103 MS90L4	BKM1103 90B5/B14	90L4		
	27	473	50	51.37	6240	1.4					
	24	557	60	59.22	6540	1.3					
		29	460	50	48.86	6130	1.6	BKM1102 MS90L4	BKM1102 BKM110B	90L4	
		34	388	40	41.26	5800	1.9				
		46	289	30	30.67	5250	2.6				
		54	244	25	25.90	4960	3.1				
		68	195	20	20.73	4610	3.3				
		93	142	15	15.11	4150	3.7				
		15.2	867	60	59.22	7580	0.86				BKM1102 MS100L6
		18.4	715	50	48.86	7110	1.0				
		22	604	40	41.26	6720	1.2				
		29	449	30	30.67	6090	1.7				
		35	379	25	25.90	5750	2.0				
	43	304	20	20.73	5340	2.1					
	60	221	16	15.11	4810	2.4					
	70	188	12.5	12.84	4550	4.0					
	88	150	10	10.27	4220	4.3					
	120	110	7.5	7.49	3800	4.7					
2.2	46	418	30	30.24	3720	0.84	BKM0752 MS100L1-4	BKM0752 100B5/B14	100L1-4		
	56	348	25	25.19	3500	0.86					
	71	274	20	19.84	3230	0.88					
	93	208	15	15.09	2950	0.96					
	112	172	12.5	12.49	2770	1.7					
	142	136	10	9.84	2550	1.8					
		187	103	7.5	7.48	2330	1.9				
		72	268	12.5	12.49	3210	1.1	BKM0752 MS112M6	BKM0752 112B5/B14	112M6	
		91	211	10	9.84	2960	1.1				
		120	161	7.5	7.48	2700	1.2				
		45	422	60	62.43	4760	1.1	BKM0903 MS90L2	BKM0903 90B5/B14	90L2	
		57	332	50	49.18	4390	1.1				
		35	554	40	40.13	5170	0.87	BKM0902 MS100L1-4	BKM0902 100B5/B14	100L1-4	
		46	418	30	30.24	4710	1.2				
		56	348	25	25.19	4430	1.4				
	71	274	20	19.84	4090	1.4					
	93	208	15	15.09	3730	1.4					
	112	172	12.5	12.49	3510	2.8					
	142	136	10	9.84	3240	2.8					
	187	103	7.5	7.48	2950	2.9					

性能参数



SHUNDA TRANSMISSION

## 性能参数 / PERFORMANCE PARAMETER

$P_{1n}$ [KW]	$n_2$ [r/min]	$M_{2max}$ [Nm]	$i$		$F_{r2}$ [N]	K				
			公称 Nominal	实际 Actual						
2.2	36	541	25	25.19	5130	0.9	BKM0902 MS112M6	BKM0902 112B5/B14	112M6	
	45	426	20	19.84	4740	0.9				
	60	324	15	15.09	4330	0.93				
	72	268	12.5	12.49	4060	1.8				
	91	211	10	9.84	3750	1.8				
	120	161	7.5	7.48	3420	1.9				
	22	874	125	129.48	6740	0.86	BKM1103 MS90L2	BKM1103 90B5/B14	90L2	
	27	700	100	103.64	6260	0.93				
	37	510	75	75.55	5630	1.0				
	44	433	60	64.18	5330	1.7				
	55	347	50	51.37	4950	1.9				
	24	818	60	59.22	6540	0.92	BKM1102 MS100L1-4	BKM1102 100B5/B14	100L1-4	
	29	675	50	48.86	6130	1.1				
	34	570	40	41.26	5800	1.3				
	46	423	30	30.67	5250	1.8				
	54	358	25	25.90	4960	2.1				
	68	286	20	20.73	4610	2.3				
	93	209	15	15.11	4150	2.5				
	109	177	12.5	12.84	3930	4.2				
	136	142	10	10.27	3650	4.6				
	187	103	7.5	7.49	3280	5.0				
	29	659	30	30.67	6090	1.1	BKM1102 MS112M6	BKM1102 112B5/B14	112M6	
	35	556	25	25.90	5750	1.3				
	43	445	20	20.73	5340	1.5				
60	325	15	15.11	4810	1.6					
70	276	12.5	12.84	4550	2.7					
88	221	10	10.27	4220	2.9					
120	161	7.5	7.49	3800	3.2					
3.0	112	235	12.5	12.49	2770	1.3	BKM0752 MS100L2-4	BKM0752 100B5/B14	100L2-4	
	142	185	10	9.84	2550	1.3				
	187	141	7.5	7.48	2330	1.4				
	46	569	30	30.24	4710	0.9	BKM0902 MS100L2-4	BKM0902 100B5/B14	100L2-4	
	56	474	25	25.19	4430	1.0				
	71	374	20	19.84	4090	1.0				
	93	284	15	15.09	3730	1.1				
	112	235	12.5	12.49	3510	2.0				
	142	185	10	9.84	3240	2.1				
	187	141	7.5	7.48	2950	2.1				
	44	591	60	64.18	5330	1.3	BKM1103 MS100L2	BKM1103 100B5/B14	100L2	
	55	473	50	51.37	4950	1.4				

性能参数



SHUNDA TRANSMISSION

# 性能参数 / PERFORMANCE PARAMETER

性能参数	$P_{1n}$	$n_2$	$M_{2max}$	i	i	$F_{r2}$	K			
	[KW]	[r/min]	[Nm]	公称 Nominal	实际 Actual	[N]				
3.0	34	777	40	41.26	5800	0.97	BKM1102 MS100L2-4	BKM1102 100B5/B14	100L2-4	
	46	577	30	30.67	5250	1.3				
	54	488	25	25.90	4960	1.5				
	68	390	20	20.73	4610	1.7				
	93	284	15	15.11	4150	1.8				
	109	242	12.5	12.84	3930	3.1				
	136	193	10	10.27	3650	3.4				
	187	141	7.5	7.49	3280	3.7				
	35	759	25	25.90	5750	1.0	BKM1102 MS132S6	BKM1102 132B5	132S6	
	43	607	20	20.73	5340	1.1				
	60	443	15	15.11	4810	1.2				
	70	376	12.5	12.84	4550	2.0				
	88	301	10	10.27	4220	2.2				
	120	219	7.5	7.49	3800	2.4				
	112	314	12.5	12.49	2770	0.96	BKM0752 MS112M4	BKM0752 112B5/B14	112M4	
	142	247	10	9.84	2550	1.0				
	187	188	7.5	7.48	2330	1.1				
	112	314	12.5	12.49	3510	1.5	BKM0902 MS112M4	BKM0902 112B5/B14	112M4	
142	247	10	9.84	3240	1.5					
187	188	7.5	7.48	2950	1.6					
46	770	30	30.67	5250	1.0	BKM1102 MS112M4				BKM1102 112B5/B14
54	650	25	25.90	4960	1.2					
68	520	20	20.73	4610	1.2					
93	379	15	15.11	4150	1.4					
109	322	12.5	12.84	3930	2.3					
136	258	10	10.27	3650	2.5					
187	188	7.5	7.49	3280	2.8					
5.5	68	716	20	20.73	4610	0.9	BKM1102 MS132S4	BKM1102 132B5	132S4	
	93	522	15	15.11	4150	1.0				
	109	443	12.5	12.84	3930	1.7				
	136	354	10	10.27	3650	1.8				
	187	259	7.5	7.49	3280	2.0				



SHUNDA TRANSMISSION

## 性能参数 / PERFORMANCE PARAMETER

### BKM.. HS性能参数 / Performance Parameter

$n_1=1400r/min$

$M_{2max}$ [Nm]	$n_2$ [r/min]	i 公称 Nominal	i 实际 Actual	$P_{1n}$ [kW]	$F_{r2}$ [N]	$F_{r1}$ [N]	
130	4.8	300	291.79	0.07	4100	400	BKM0503..HS
130	5.7	250	244.29	0.09	4100	400	
130	7.0	200	200.44	0.11	4100	400	
130	9.5	150	146.67	0.14	4000	400	
130	11.6	125	120.34	0.18	3770	400	
100	13.9	100	101.04	0.16	3560	400	
80	18.8	75	74.62	0.17	3220	400	
130	22	60	62.36	0.34	3030	400	
100	27	50	52.36	0.31	2860	400	
130	24	60	58.36	0.35	2960	400	
130	29	50	48.86	0.42	2790	400	
130	35	40	40.09	0.52	2610	400	
130	48	30	29.33	0.71	2350	400	
130	58	25	24.07	0.86	2200	400	
100	69	20	20.21	0.79	2080	400	
80	94	15	14.92	0.85	1880	400	
130	112	12.5	12.47	1.7	1770	400	
100	134	10	10.47	1.5	1670	400	
80	181	7.5	7.73	1.6	1510	400	
200	4.6	300	302.50	0.11	4800	400	BKM0633..HS
200	5.7	250	243.57	0.13	4800	400	
180	7.1	200	196.43	0.15	4800	400	
200	9.2	150	151.56	0.21	4650	400	
180	11.5	125	122.22	0.24	4330	400	
150	13.8	100	101.27	0.24	4070	400	
110	19.1	75	73.33	0.24	3650	400	
180	22	60	63.33	0.46	3480	400	
150	27	50	52.48	0.47	3270	400	
200	23	60	60.50	0.53	3430	530	BKM0632..HS
200	29	50	48.71	0.65	3190	530	
180	36	40	39.29	0.73	2970	530	
200	46	30	30.31	1.1	2720	530	
180	57	25	24.44	1.2	2530	530	
150	69	20	20.25	1.2	2380	530	
110	95	15	14.67	1.2	2130	530	
180	110	12.5	12.67	2.3	2030	530	
150	133	10	10.50	2.3	1910	530	
110	184	7.5	7.60	2.3	1710	530	

性能参数



SHUNDA TRANSMISSION

## 性能参数 / PERFORMANCE PARAMETER

$M_{2max}$ [Nm]	$n_2$ [r/min]	i 公称 Nominal	i 实际 Actual	$P_{1n}$ [kW]	$F_{r2}$ [N]	$F_{r1}$ [N]	
350	4.7	300	297.21	0.19	6500	560	BKM0753..HS
350	5.8	250	240.86	0.24	6500	560	
300	7.0	200	200.66	0.24	6500	560	
350	9.3	150	151.20	0.38	6500	560	
300	11.1	125	125.95	0.39	5980	560	
240	14.1	100	99.22	0.39	5520	560	
200	18.6	75	75.45	0.43	5040	560	
300	22	60	62.43	0.78	4730	560	
240	28	50	49.18	0.79	4370	560	
350	24	60	59.44	0.94	4660	860	BKM0752..HS
350	29	50	48.18	1.2	4340	860	
300	35	40	40.13	1.2	4080	860	
350	46	30	30.24	1.8	3720	860	
300	56	25	25.19	1.9	3500	860	
240	71	20	19.84	1.9	3230	860	
200	93	15	15.09	2.1	2950	860	
300	112	12.5	12.49	3.8	2770	860	
240	142	10	9.84	3.9	2550	860	
200	187	7.5	7.48	4.3	2330	860	
500	4.7	300	295.18	0.27	8300	560	BKM0903..HS
500	5.8	250	240.89	0.34	8300	560	
480	7.0	200	200.66	0.39	8300	560	
500	9.3	150	151.20	0.54	8050	560	
480	11.1	125	125.95	0.62	7580	560	
380	14.1	100	99.22	0.62	7000	560	
300	18.6	75	75.45	0.65	6390	560	
480	22	60	62.43	1.3	6000	560	
380	28	50	49.18	1.3	5540	560	
500	24	60	59.04	1.3	5890	1260	BKM0902..HS
500	29	50	48.18	1.7	5500	1260	
480	35	40	40.13	1.9	5170	1260	
500	46	30	30.24	2.6	4710	1260	
480	56	25	25.19	3.0	4430	1260	
380	71	20	19.84	3.1	4090	1260	
300	93	15	15.09	3.2	3730	1260	
480	112	12.5	12.49	6.1	3510	1260	
380	142	10	9.84	6.2	3240	1260	
300	187	7.5	7.48	6.4	2950	1260	

性能参数



SHUNDA TRANSMISSION

## 性能参数 / PERFORMANCE PARAMETER

$M_{2max}$ [Nm]	$n_2$ [r/min]	i 公称 Nominal	i 实际 Actual	$P_{in}$ [kW]	$F_{i2}$ [N]	$F_{r1}$ [N]	
750	4.7	300	296.10	0.40	10000	740	BKM1103..HS
750	5.7	250	244.29	0.50	10000	740	
750	6.8	200	206.29	0.59	9920	740	
750	9.1	150	153.33	0.80	8980	740	
750	10.8	125	129.48	0.94	8490	740	
650	13.5	100	103.64	1.0	7880	740	
520	18.5	75	75.55	1.1	7090	740	
750	22	60	64.18	1.9	6720	740	
650	27	50	51.37	2.1	6240	740	
750	24	60	59.22	2.0	6540	1490	
750	29	50	48.86	2.4	6130	1490	
750	34	40	41.26	2.9	5800	1490	
750	46	30	30.67	3.9	5250	1490	
750	54	25	25.90	4.6	4960	1490	
650	68	20	20.73	5.0	4610	1490	
520	93	15	15.11	5.5	4150	1490	
750	109	12.5	12.84	9.3	3930	1490	
650	136	10	10.27	10.1	3650	1490	
520	187	7.5	7.49	11.1	3280	1490	

性能参数



SHUNDA TRANSMISSION

# 外形尺寸图表 / OUTLINE DIMENSION SHEET

## ●BKM...IEC外形尺寸 / Outline Dimension

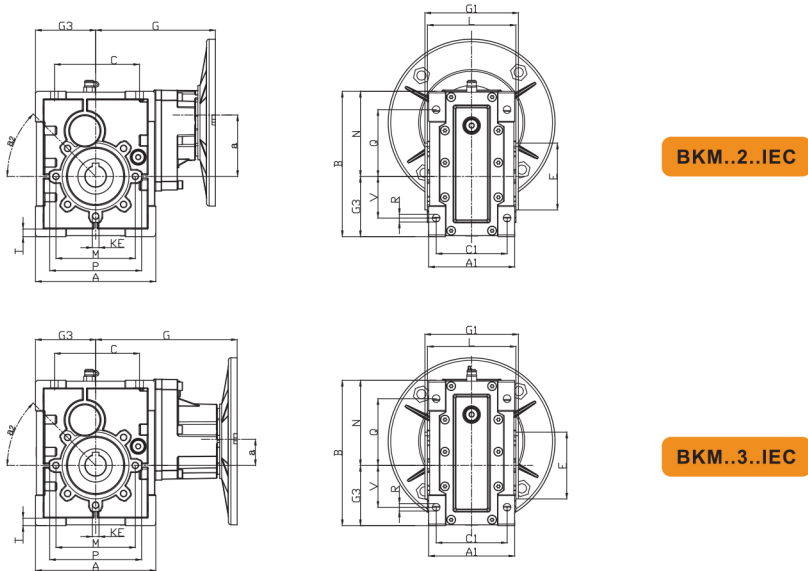

外形尺寸图表

BKM	C	A	B	G	G <sub>3</sub>	a	C <sub>1</sub>	KE	a <sub>2</sub>	L	G <sub>1</sub>	M	E <sub>hs</sub>	A <sub>1</sub>	R	P	Q	N	T	V	kg
0502	80	120	155	132.5	60	57	70	4-M8*12	45°	87	92	85	70	85	8.5	100	75	95	7	40	4.5
0503	80	120	155	148	60	21.5	70	4-M8*12	45°	87	92	85	70	85	8.5	100	75	95	7	40	5
0632	100	144	174	143.5	72	64.5	85	7-M8*14	45°	106	112	95	80	103	8.5	110	80	102	9	50	6.3
0633	100	144	174	169	72	29	85	7-M8*14	45°	106	112	95	80	103	8.5	110	80	102	9	50	7
0752	120	172	205	174	86	74.5	90	7-M8*16	45°	114	120	115	95	112	11	140	93	119	10	60	9.9
0753	120	172	205	203	86	30.5	90	7-M8*16	45°	114	120	115	95	112	11	140	93	119	10	60	10.9
0902	140	206	238	192	103	88	100	7-M10*22	45°	134	140	130	110	130	13	160	102	135	11	70	13.9
0903	140	206	238	220	103	44	100	7-M10*22	45°	134	140	130	110	130	13	160	102	135	11	70	14.9
1102	170	255	295	241.5	127.5	108	115	7-M10*25	45°	148	155	165	130	144	14	185	125	167.5	16	85	28
1103	170	255	295	271.5	127.5	52	155	7-M10*25	45°	148	155	165	130	144	14	185	125	167.5	16	85	30

注：重量 (kg) 不包含电机的重量。  
 Note: Weight(kg) without the weight of motor.



# 外形尺寸图表 / OUTLINE DIMENSION SHEET

## ●BKM..MS..外形尺寸 / Outline Dimension

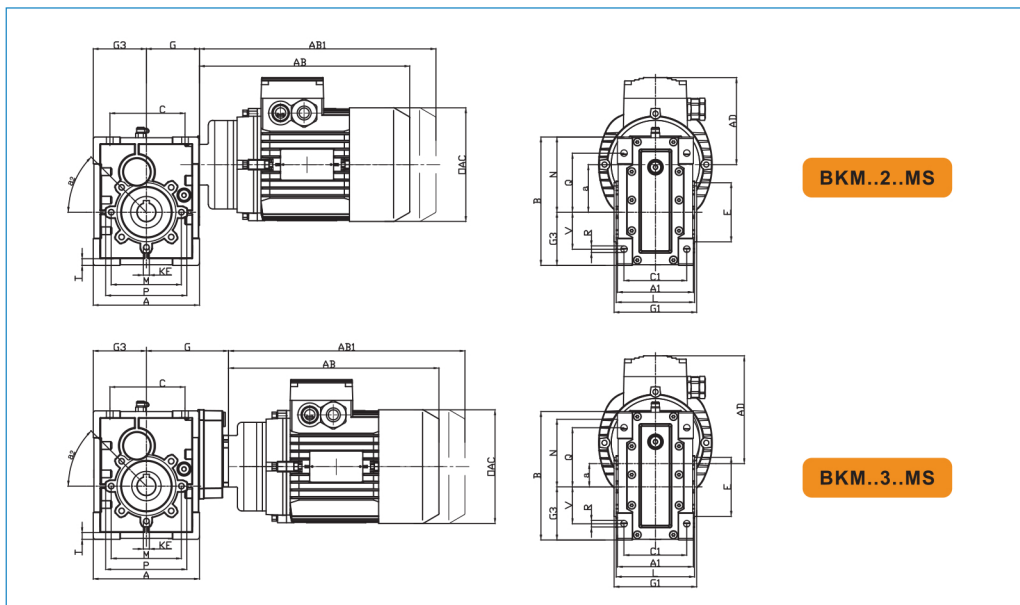

**BKM..2..MS**

**BKM..3..MS**

外形尺寸图表

BKM	C	A	B	G	G <sub>3</sub>	a	C <sub>1</sub>	KE	a <sub>2</sub>	L	G <sub>1</sub>	M	E <sub>h8</sub>	A <sub>1</sub>	R	P	Q	N	T	V
0502	80	120	155	61	60	57	70	4-M8*12	45°	87	92	85	70	85	8.5	100	75	95	7	40
0503	80	120	155	95	60	21.5	70	4-M8*12	45°	87	92	85	70	85	8.5	100	75	95	7	40
0632	100	144	174	72	72	64.5	85	7-M8*14	45°	106	112	95	80	103	8.5	110	80	102	9	50
0633	100	144	174	106	72	29	85	7-M8*14	45°	106	112	95	80	103	8.5	110	80	102	9	50
0752	120	172	205	87	86	74.5	90	7-M8*16	45°	114	120	115	95	112	11	140	93	119	10	60
0753	120	172	205	126	86	30.5	90	7-M8*16	45°	114	120	115	95	112	11	140	93	119	10	60
0902	140	206	238	104	103	88	100	7-M10*22	45°	134	140	130	110	130	13	160	102	135	11	70
0903	140	206	238	143	103	44	100	7-M10*22	45°	134	140	130	110	130	13	160	102	135	11	70
1102	170	255	295	127.5	127.5	108	115	7-M10*25	45°	148	155	165	130	144	14	185	125	167.5	16	85
1103	170	255	295	177.5	127.5	52	155	7-M10*25	45°	148	155	165	130	144	14	185	125	167.5	16	85

MS..	63	71	80	90S	90L	100	112	132
AB	211	226	261	285	295	355	373	424
AB1	266	290	354	370	380	440	453	504
AC	120	130	145	160	160	185	200	245
AD	104	109	110	115	115	140	158	178



# 外形尺寸图表 / OUTLINE DIMENSION SHEET

## ●BKM..STM..外形尺寸 / Outline Dimension

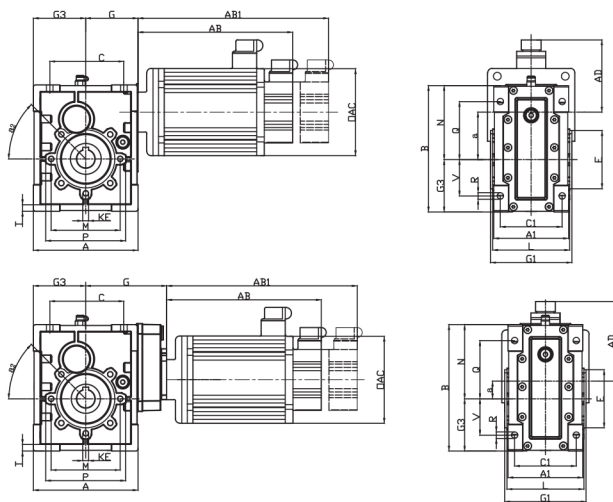

BKM..2..STM..

BKM..3..STM..

外形尺寸图表

STM	AC	AD	M006		M013		M020		M024		M035		M040		M050		M060		M077		
			AB	AB1	AB	AB1	AB	AB1	AB	AB1	AB	AB1	AB	AB1	AB	AB1	AB	AB1	AB	AB1	AB
60	60	76	142	190	167	215	-	-	-	-	-	-	-	-	-	-	-	-	-	-	-
80	80	86	-	-	154	194	-	-	181	221	209	249	221	261	-	-	-	-	-	-	-
90	86.6	89.3	-	-	-	-	-	-	180	228	202	250	212	260	-	-	-	-	-	-	-
110	110	103	-	-	-	-	159	263	-	-	-	-	222	274	234	308	242	274	-	-	-
130	130	113	-	-	-	-	-	-	-	-	-	-	196	253	201	258	209	266	222	279	-
150	150	123	-	-	-	-	-	-	-	-	-	-	-	-	-	-	-	-	-	-	-
180	180	138	-	-	-	-	-	-	-	-	-	-	-	-	-	-	-	-	-	-	-

STM	M100		M150		M172		M180		M190		M215		M230		M270		M350		M480		
	AB	AB1	AB	AB1	AB	AB1	AB	AB1	AB	AB1	AB	AB1	AB	AB1	AB	AB1	AB	AB1	AB	AB1	
130	234	286	271	352	-	-	-	-	-	-	-	-	-	-	-	-	-	-	-	-	-
150	-	-	260	333	-	-	278	351	-	-	-	-	308	381	332	405	308	381	332	405	-
180	-	-	-	-	256	328	-	-	252	334	273	345	-	-	292	364	322	394	376	448	-

AB: 不带抱闸/without brake AB1: 带抱闸/with brake M006: 伺服电机的扭矩 (0.6Nm) /servo motor (0.6Nm)  
 注: 其余尺寸参考 BKM..MS..外形尺寸 Note: The remaining size refer BKM..MS..outline dimension



# 外形尺寸图表 / OUTLINE DIMENSION SHEET

## ●BKM..HS外形尺寸 / Outline Dimension

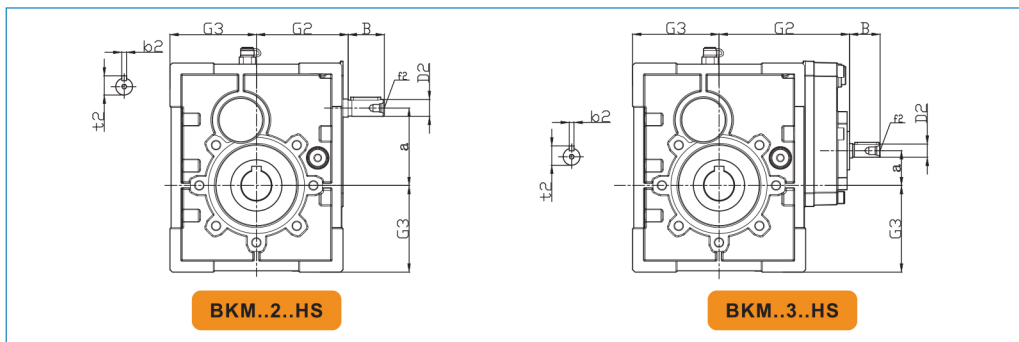

BKM	B	D <sub>2,16</sub>	G <sub>2</sub>	G <sub>3</sub>	a	b <sub>2</sub>	t <sub>2</sub>	f <sub>2</sub>
0502	23	11	65	60	57	4	12.5	-
0503	23	11	100	60	21.5	4	12.5	-
0632	30	14	76	72	64.5	5	16	M6
0633	23	11	111	72	29	4	12.5	-
0752	40	16	91	86	74.5	5	18	M6
0753	30	14	132	86	30.5	5	16	M6
0902	40	19	107	103	88	6	21.5	M6
0903	30	14	146	103	44	5	16	M6
1102	50	24	132	127.5	108	8	27	M6
1103	40	19	181	127.5	52	6	21.5	M6

外形尺寸图表

## ●BKM..空心输出轴尺寸 / Hollow Output Shaft Dimension

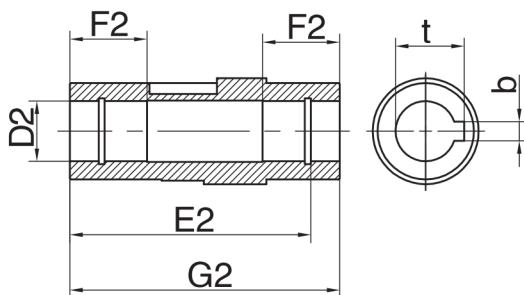

BKM	S	E	G1	D <sub>hb</sub>	b	t
050	30	77	92	20	6	22.8
				24	8	27.3
063	36	97	112	25	8	28.3
				28	8	31.3
075	40	105	120	28	8	31.3
				30	8	33.3
090	45	122	140	35	10	38.3
				38	10	41.3
110	50	131	155	40	12	43.3
				42	12	45.3



SHUNDA TRANSMISSION

# 连接尺寸图表 / GONNECTING DIMENSION SHEET

## ●BKM...F输出法兰尺寸 / Output Flange Dimension

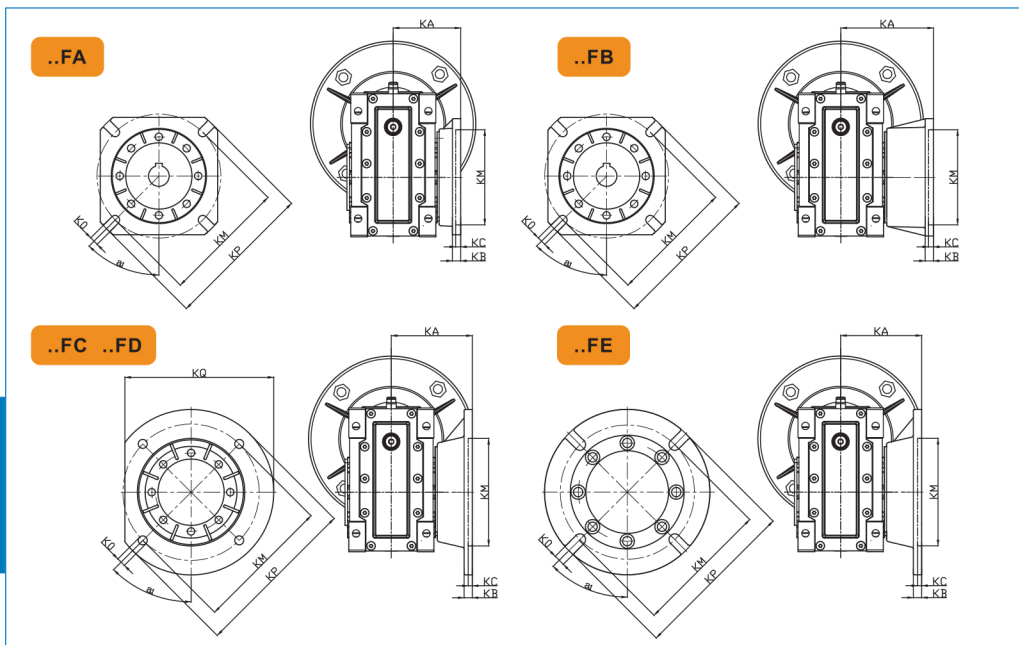

连接尺寸图表

BKM	FA								
	a1	KA	KB	KC	BKM	KN <sub>H</sub>	KO	KP	KQ
050	45	90	9	5	85	70	11(N=4)	125	110
063	45	82	10	6	150	115	11(N=4)	180	142
075	45	111	13	6	165	130	14(N=4)	200	170
090	45	111	13	6	175	152	14(N=4)	210	200
110	45	139	15	6	230	170	14(N=8)	280	260

BKM	FC								
	a1	KA	KB	KC	BKM	KN <sub>H</sub>	KO	KP	KQ
050	45	80	10	5	130	110	9(N=4)	160	-
063	45	98	10	5	165	130	11(N=4)	200	-
090	45	110	17	6	165	130	11(N=4)	200	-

BKM	FD								
	a1	KA	KB	KC	BKM	KN <sub>H</sub>	KO	KP	KQ
050	45	72	14.5	5	115	95	11(N=4)	140	-
063	45	107	10	5	165	130	11(N=4)	200	-
090	45	151	13	6	175	152	14(N=4)	210	-

BKM	FB								
	a1	KA	KB	KC	BKM	KN <sub>H</sub>	KO	KP	KQ
050	45	120	9	5	85	70	11(N=4)	125	110
063	45	112	10	6	150	115	11(N=4)	180	142
075	45	90	13	6	130	110	14(N=4)	160	-
090	45	122	18	6	215	180	14(N=4)	250	-
110	-	-	-	-	-	-	-	-	-

BKM	FE								
	a1	KA	KB	KC	BKM	KN <sub>H</sub>	KO	KP	KQ
050	-	-	-	-	-	-	-	-	-
063	45	80.5	16.5	5	130	110	11(N=4)	160	-
090	-	-	-	-	-	-	-	-	-





SHUNDA TRANSMISSION

# 连接尺寸图表 / GONNECTING DIMENSION SHEET

## ●BKM..F..输出法兰尺寸 / Output Flange Dimension

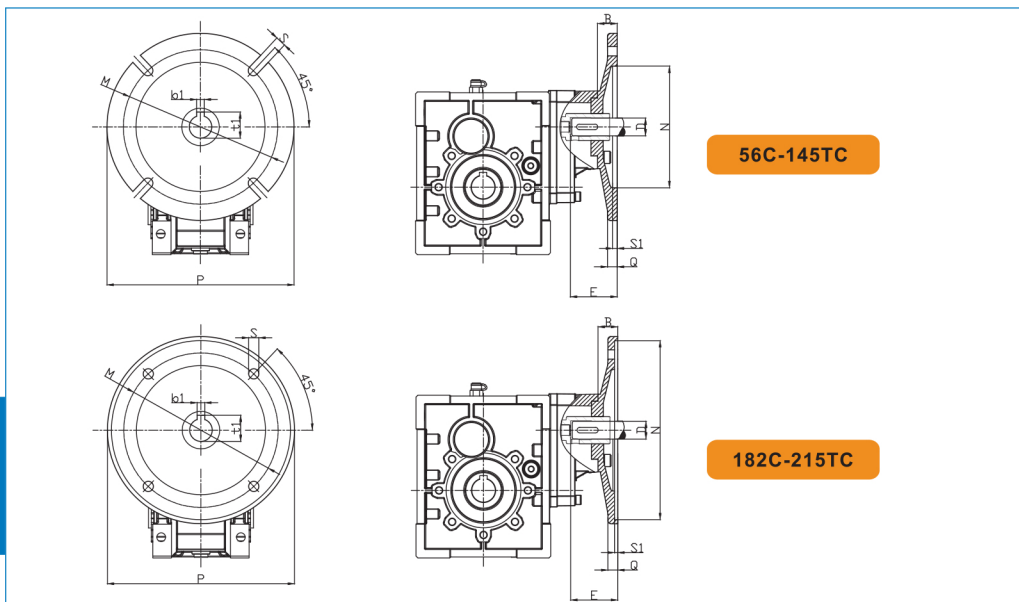

56C-145TC

182C-215TC

连接尺寸图表

BKM	NEMA Flange	B	D	E	b1	t1	M	N	P	Q	S	S1
050	56C	1.15	0.625	2.06	0.188	0.713	5.875	4.5	6.5	0.433	0.413	0.177
063	56C	1.22	0.625	2.06	0.188	0.713	5.875	4.5	6.5	0.433	0.413	0.177
	143TC	1.22	0.875	2.12	0.188	0.963	5.875	4.5	6.5	0.433	0.413	0.177
	145TC											
075 090	56C	1.50	0.625	2.06	0.188	0.713	5.875	4.5	6.5	0.433	0.413	0.177
	143TC	1.50	0.875	2.12	0.188	0.963	5.875	4.5	6.5	0.433	0.413	0.177
	145TC											
	182TC	1.50	1.126	2.62	0.250	1.240	7.250	8.5	9.0	0.472	0.551	0.197
	184TC											
110	56C	1.89	0.625	2.06	0.188	0.713	5.875	4.5	6.5	0.433	0.413	0.177
	143TC	1.89	0.875	2.12	0.188	0.983	5.875	4.5	6.5	0.433	0.413	0.177
	145TC											
	182TC	1.89	1.125	2.62	0.250	1.240	7.250	8.5	9.0	0.472	0.551	0.197
	184TC											
	213TC	1.89	1.375	3.12	0.312	1.517	7.250	8.5	9.0	0.472	0.551	0.197
215TC												



# 连接尺寸图表 / GONNECTING DIMENSION SHEET

## ●BKM..ST..伺服电机输入法兰尺寸/Servo Motor Input Flange Dimension

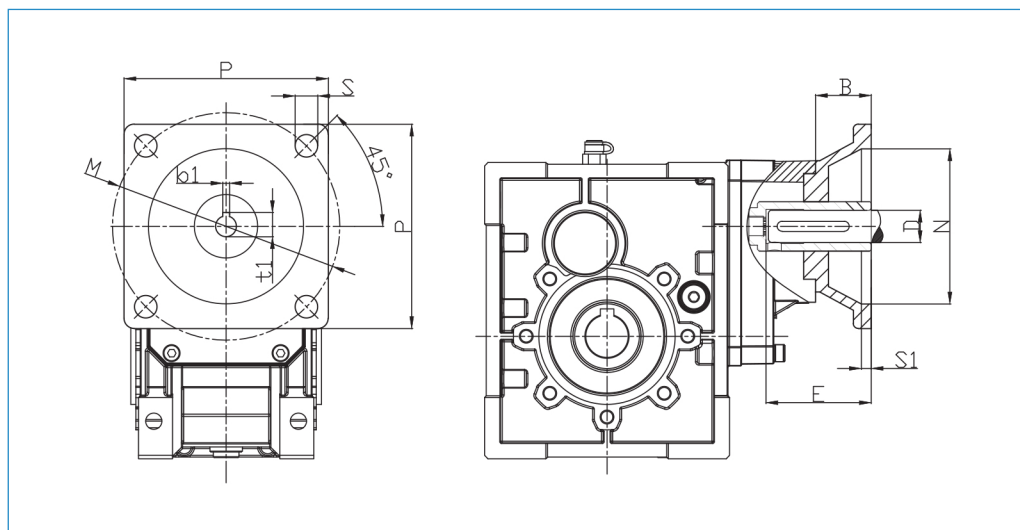

连接尺寸图表

BKM	P	B	D <sub>h7</sub>	E	b1	t1	M	N	S	S1
050	60	35	14	30	5	16.3	70	50	5.5	4
	80	28	19	35	6	21.8	90	70	6	5
	90	30	16	35	5	18.3	100	80	6.5	5
	110	26	19	55	6	21.8	130	95	9	6
	130	32	22	57	6	24.8	145	110	9	6
063	60	40	14	30	5	16.3	70	50	5.5	4
	80	21	19	35	6	21.8	90	70	6	5
	90	21	16	35	5	18.3	100	80	6.5	5
	110	46	19	55	6	21.8	130	95	9	6
	130	40	22	57	6	24.8	145	110	9	6
075	110	47	19	55	6	21.8	130	95	9	6
	130	40	22	57	6	24.8	145	110	9	6
	150	38	28	58	8	31.3	165	130	11	6
090	110	47	19	55	6	21.8	130	95	9	6
	130	40	22	57	6	24.8	145	110	9	6
	150	38	28	58	8	31.3	165	130	11	6
110	130	38	22	57	6	24.8	145	110	9	6
	150	38	28	58	8	31.3	165	130	11	6
	180	38	35	65	10	38.3	200	114.3	13.5	6



SHUNDA TRANSMISSION

## 附件尺寸图表 / ACCESSORIES OUTLINE DIMENSION SHEET

### 输出轴 / Output Shafts

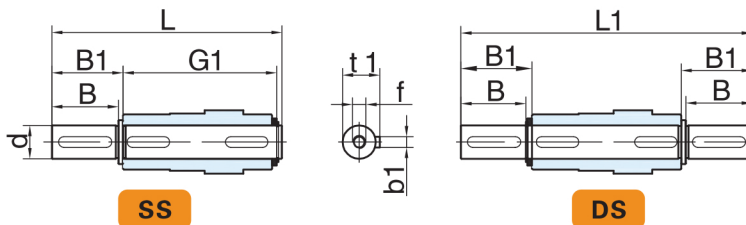

BKM	d <sub>he</sub>	B	B1	G1	L	L1	f	b1	t1
050	25	50	53.5	92	153	199	M10*27	8	28
063	25	50	53.5	112	173	219	M10*27	8	28
075	28	60	63.5	120	192	247	M10*27	8	31
090	35	80	84.5	140	234	309	M12*34	10	38
110	42	80	84.5	155	249	324	M16*42	12	45

附件尺寸图表

### 扭力臂/Torque Arm

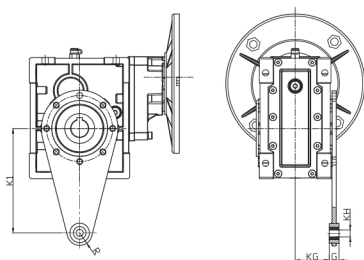

BKM	K1	G	K1	KH	R
050	100	14	38.5	10	18
063	150	14	49	10	18
075	200	25	47.5	20	30
090	200	25	57.5	20	30
110	250	30	62	25	35

### 防尘盖/Cover

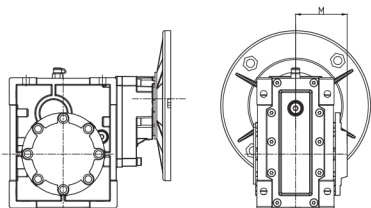

BKM	M
050	58
063	69
075	74
090	86
110	94



# 安装方位图 / INSTALLATION POSITIONS DIAGRAM

## 输出法兰位置 / Position diagram for output flange

FA1,FB1,FC1,FD1,FE1

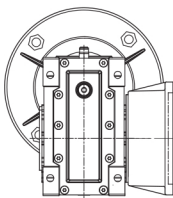

FA2,FB2,FC2,FD2,FE2

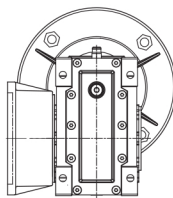

如果没有特殊要求，一般按出厂标准位置如图F..1方式和B3位置提供。

Unless specified otherwise,the gear units is supplied with the flange in pos.F..1 referred to position B3.

## 单向输出轴位置/Position diagram for single output shaft

SS1

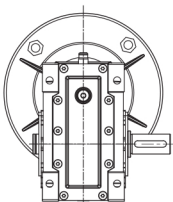

SS2

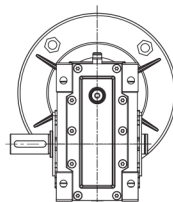

如果没有特殊要求，一般按出厂标准位置如图SS1方式和B3位置提供。

Unless specified otherwise,the gear units is supplied with the flange in pos.SS1 referred to position B3.

## 电机连接盒方位/Position of motor terminal box

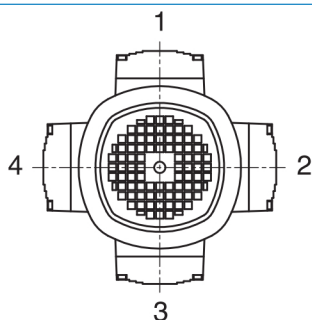

如对接线盒位置有特殊要求，请在下单时如图所示来指定接线盒安装方位。

In the case of specific requirement, when ordering, specify the position of the terminal box as shown in the diagram.

## 符号释义/Symbols Used

符号/Symbols	含义/Meaning
	排气阀 Breather valve
	油位塞 Oil level plug
	放油塞 Oil drain plug



SHUNDA TRANSMISSION

# 安装方位图 / INSTALLATION POSITIONS DIAGRAM

## BKM..安装方位 / Mounting Position

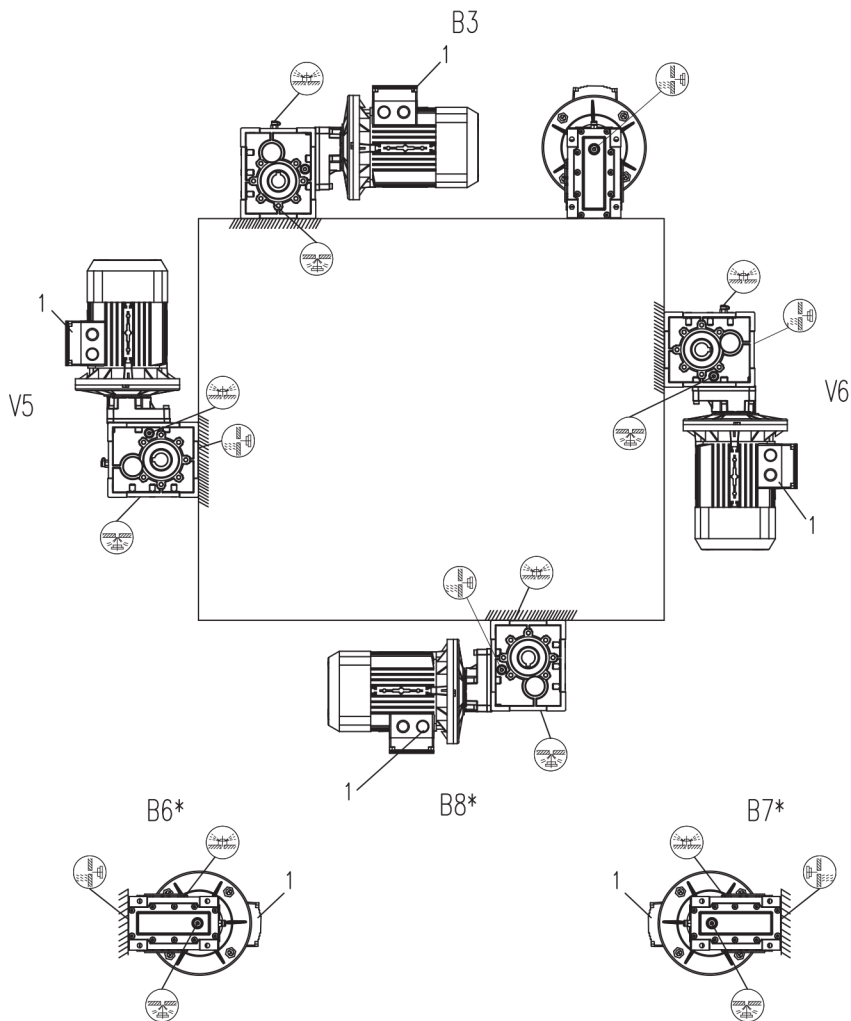

安装方位图

\*表示在此安装方式，不能仅凭油位塞加注润滑油，油位需高出油位塞，加注量按表内所示。

It means the lubricant can't be added according to the oil level line plug, but also higher the plug to fill quantity as shown in the table.



SHUNDA TRANSMISSION

## 润滑油 / LUBRICANTS

	环境温度 ( °C ) Ambient Tempreatur ( °C )	ISO粘度 ISO Viscosity Class	 SHELL	 MOBIL	 BP	润滑油类型 lubrication type
KM..	-10 ~ +40	VG220	Shell Omala 220	Mobil gear 630	BP Energol GX-XP 220	矿物油 Mineral oil
	-20 ~ +25	VG150 VG100	Shell Omala 100	Mobil gear 627	BP Energol GX-XP 100	
	-30 ~ +10	VG110-46 VG32	Shell Omala T32	Mobil D.T.E.13M		
	-40 ~ -20	VG22 VG15	Shell Omala T15	Mobil D.T.E.11M	BP Energol HLP-HM 15	
	-40 ~ +80	VG220	Shell Omala HD220	Mobil SHC630		合成油 Synthetic oil
	-40 ~ +40	VG150		Mobil SHC629		
	-40 ~ +10	VG32		Mobil SHC624		

润滑油



# 润滑油 / LUBRICANTS

规定的加注量为参考值。精确值的变化与级数和传动比有关。请您在加注润滑油时一定要注意油位螺栓所指示的精确油量。后期调整安装方式时，您必须根据改变后的安装方式相应调整加注润滑油。下表列出了不同安装方式（B3、B6、B7……）的减速机相应的标准参考润滑油注入量值。

The specified fill quantities are recommended values. The precise values vary depending on the number of stages and gear ratio. When filling, it is essential to check the oil level plug since it indicates the precise oil capacity. The following tables show guide values for lubrication fill quantities in relation to the mounting position (B3, B6, B7……)

## 润滑油加注量/Lubricant fill quantity

KM							BKM						
减速机 型号 Gear units	加注量 Fill quantity in liters 单位：升（L）						减速机 型号 Gear units	加注量 Fill quantity in liters 单位：升（L）					
	B3	B6	B7	B8	V5	V6		B3	B6	B7	B8	V5	V6
KM050B	0.32	0.3	0.2	0.2	0.35	0.25	BKM0502	0.22	0.20*	0.13*	0.15	0.25	0.14
KM050C	0.48	0.46	0.45	0.48	0.52	0.46	BKM0503 <sup>#</sup>	0.08	0.05	0.05	0.06	0.09	0.10
KM063B	0.6	0.56	0.4	0.42	0.62	0.4	BKM0632	0.42	0.35*	0.24*	0.22	0.46	0.25
KM063C	1.1	1	1	1.1	1.3	0.9	BKM0633 <sup>#</sup>	0.07	0.05	0.05	0.06	0.09	0.10
KM075B	0.9	0.7	0.65	0.9	1.2	0.7	BKM0752	0.70	0.58*	0.42*	0.42	0.75	0.45
KM075C	1.5	1.5	1.45	1.5	1.8	1.45	BKM0753 <sup>#</sup>	0.15	0.11	0.11	0.11	0.17	0.50
KM090B	1.5	1.3	1.2	1.2	1.8	1.25	BKM0902	1.21	0.95*	0.72*	0.67	1.30	0.74
KM090C	2.5	2.3	2.1	2.45	2.8	2.2	BKM0903 <sup>#</sup>	0.15	0.11	0.11	0.11	0.17	0.20
KM110B	2.5	2.2	1.9	2.1	3	2	BKM1102	2.15	1.70*	1.10*	1.25	2.20	1.20
KM110C	4.7	4.5	4.3	4.7	5	4.5	BKM1103 <sup>#</sup>	0.25	0.17	0.17	0.20	0.32	0.36

#:采用3级传动减速器时，各自加注3级箱体和2级箱体的润滑油，润滑油互不相通，表中的加注量为3级箱体润滑油加注量。

#: Means the oil quantity in the 3rd stage housing, as this one is separated from the 2nd housing, please fill them separately while in 3 stages.

\*:表示在此安装方式，不能仅凭油位塞加注润滑油，油位需高出油位塞，加注量按表中所示。

\*: It means the lubricant can't be according to the oil level line plug, but also higher the plug the fill quantity as shown in the table.



# 维护 / MAINTENANCE

1) 对于齿轮箱，首次换油必须在工作大约300小时（齿轮磨合期）后进行，在换油时应使用合适的清洗剂小心地冲洗齿轮箱，不得将矿物油和合成油混合。

2) 每3000工作小时，最低程度半年，应检测油以及油位，油封密封不严引起滴漏的常规检测，若是IEC输入的减速机，则检测检查弹性体，必要时进行更换。

3) 根据不同的工作条件（见下图）而定，最长每三年检测一次，更换矿物油，更换轴承润滑油脂。

4) 根据不同的工作条件而定，更换输出轴上的油封。

5) 产品出现故障时，不要拆卸部件，与本公司售后服务部门联系（需提供减速机规格、出厂日期、编号、已使用时间、主机名称、主机生产单位和故障类型）后，再采取合理的措施。

1) For gear units, first oil change should be after about 300hours ( run-in period ).The right lotion is required to clean the gear units with care.Never mix the synthetic oil and mineral oil together.

2) Every 3000 working time, at least every 6 months, you have to check the oil and oil level, the seals visually for leakage.For IEC input gear units, the elastomer should be tested or replaced if necessary.

3) Depending on the operating conditions ( see chart below ) , every 3 years at the latest for inspection is needed.Then change the mineral oil and replace the bearing grease.

4) Depending on the operating conditions, change the oil seals on output shaft.

5) Once the malfunctions appear, stop disassembling the parts, and firstly please contact the customer service ( the information about specification, delivery date, series number, time used, name of machine, machine manufacturer, malfunction problems is required ) , then take the reasonable measures.

维护

适用于正常环境条件下标准减速机的更换时间间隔  
Oil change intervals for standard gear units under normal environmental conditions

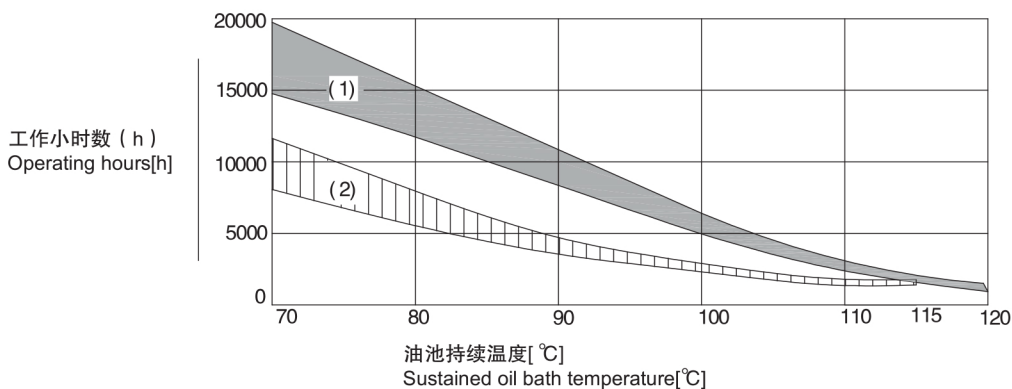

● 每种机油类型的平均值为70°C Average value per oil type at 70°C  
( 1 ) 合成油 Synthetic oil ( 2 ) 矿物油 Mineral oil



SHUNDA TRANSMISSION

## 存放 / STORAGE 订货须知 / NOTICE FOR ORDER

### 存放 / Storage

- 1) 有顶棚，防雨雪，无振动。
- 2) 在设备和地面之间垫放木块或其他材料。
- 3) 开箱后暂不使用的齿轮减速机在其加工表面涂上防锈油，并及时放回包装箱内。
- 4) 在定期检查的情况下，两年以及更长时间。在进行检查时，应检查清洁度和机械损伤，检查防锈层是否完好。

- 1) Under roof, protected against rain and snow, no shock loads.
- 2) Underlay the block and other material between the ground and equipment.
- 3) The opened but not used gear units should be added with the anti-corrosive oil on its surface, and then return to the packing containers timesly.
- 4) Two years or more given regular inspections. Check for cleanliness and mechanical damage as part of the inspection, Check corrosion protection.

### 订货须知 / Notice for order

减速机订单请向我们提供以下信息：

- 1) 减速机型号标记（减速机类型、速比、功率和安装方式）。
- 2) 减速机表面喷涂颜色，一般按银灰色提供。
- 3) 订购数量。
- 4) 其他特殊要求。
- 5) 单位名称、联系人、联系电话。

Please offer the following information when place the orders:

- 1) the model mark of the gear units ( type, ratio, power and mounting position ) .
- 2) generally the gear units paint in silver.
- 3) quantity ordered.
- 4) other special requirements.
- 5) company, contact and telephone.



## 运转故障 / MULTIFUNCTIONS

故障 Problem	可能的原因 Possible cause	解决方法 Remedy
异常、均匀的运转噪声 Unusual, regular running noise	A. 滚动/碾压噪声：轴承损坏 B. 冲击型噪声：齿轮啮合不均匀 A. Meshing/grinding noise: Bearing damage. B. Knocking noise: Irregularity in the gearing	A.检测润滑油，更换轴承 B.请向客户服务部咨询 A. Check the oil, change bearings B. Contact customer service
异常、不均匀的运转噪声 Unusual, irregular running noise	机油中有异物 Foreign bodies in the oil	· 检测润滑 · 停止运转传动装置，向客户服务部咨询 · Check the oil · Stop the drive, contact customer service
机油泄漏 1 ) · 在减速机盖上 · 在电机凸缘上 · 在电机轴密封圈上 · 在减速机凸缘上 · 在输出端轴密封圈上 Oil leaking 1 ) · From the gear cover plate · From the motor flange · From the motor oil seal · From the gear unit flange · From the output end oil sea	A. 减速机底座上的橡胶密封发生渗漏 B. 密封圈损坏 C. 减速机没有排气 A. Rubber seal on the gear cover plate leaking B. Seal defective C. Gear unit not vented	A. 拧紧各个外盖上的螺钉并且观察减速机。如果机油继续泄露，请向客服服务部咨询 B. 请向客户服务部咨询 C. 给减速机排气(参见“安装方式”) A. Tighten the bolts on the gear cover plate and observe the gear unit. Oil still leaking: Contact customer service B. Contact customer service C. Vent the gear unit ( see “Mounting Positions” )
机油从排气阀门旁渗出 Oil leaking from breaking valve	A. 机油太多 B. 传动装置安装方式错误 C. 频繁冷启动（机油起泡沫）和/或者较高的油位 A. Too much oil B. Drive operated in incorrect mounting position C. Frequent cold starts ( oil foams ) and/or high oillevel	A. 修正油量（参见“润滑油”） B. 正确安装排气阀并且矫正油位（参见“安装方式”） A. Correct the oil level ( see Sec. “Inspection and Maintenance” ) B. Mount the breather valve correctly ( see Sec. “Mounting Positions” ) and correct the oil level ( see “Lubricants” )
尽管电机在运转或者传动轴已经被驱动，但是传动轴不转动 Output shaft does not turn although the motor is running or the input shaft is rotated	减速机中的轴轮毂联接断裂 Connection between shaft and hub in gear unit interrupted	将减速机或减速电机送修 Send in the gear unit/gearmotor for repair

在磨合试运转阶段（24小时的运转时间内），轴密封圈有可能出现短期内的漏油/油脂的现象  
Short-term oil/grease leakage at the oil seal is possible in the run-in phase ( 24 hours running time )



## 减速机负载特征表 / CHARGE CHARACTERISTIC CHART

## 减速机负载特征表(参考件) / Charge Characteristic Chart(for referebce)

<b>风机类 AIR BLOWERS</b>		
风机 (轴向和径向) Air blower ( axial or radial )	A	
冷却塔风扇 Fan of cooling tower	B	
引风机 Induced draught fan	B	
螺旋活塞式风机 Rotary piston type fan	B	
蜗轮式风机 Turbo-fan	A	
<b>建筑机械类 CONSTRUCTION MACHINERY</b>		
混凝土搅拌机 Concrete mixer	B	
卷扬机 Hoist	B	
路面建筑机械 Road building machinery	B	
钻孔机 Boring mill	B	
<b>化工机械类 CHEMICAL MACHINERY</b>		
搅拌机 (液体) Mixer ( liquid )	A	
搅拌机 (半液体) Mixer ( half liquid )	B	
离心机 (重型) Centrifuge ( heavy )	B	
离心机 (轻型) Centrifuge ( light )	A	
冷却滚筒** Cooling rolling drum	B	
干燥滚筒** Dry rolling drum	B	
搅拌机 Mixer	B	
<b>压缩机类 COMPRESSOR</b>		
活塞式压缩机 Piston type compressor	C	
蜗轮式压缩机 Turbo-compressor	B	
<b>传送运输机类 TRANSMISSION FREIGHTER</b>		
平板传送机 Pan conveyer	B	
平衡块升降机 Balance lifter	B	
槽式传送机 Trough conveyer	B	
带式传送机 (大件) Ribbon conveyer ( large piece )	C	
带式传送机 (碎料) Ribbon conveyer ( small piece )	B	
筒式面粉传送机 Drum-type flour conveyer	A	
链式传送机 Chain conveyer	B	
环式传送机 Ring type conveyer	B	
货物升降机 Lifter	B	
卷扬机 Hoist	B	
连杆式传送机 Crank-connecting conveyer	B	
载入升降机 Lifter	B	
螺旋式传送机 Worm conveyer	B	
钢带式传送机 Steel-band conveyer	B	
链式槽型传送机 Chain reed-type conveyer	B	
绞车运输机 Crab freighter	B	
<b>起重机类 HOIST</b>		
卷扬机齿轮传动装置 Hoist gear assembly	A	

转臂式起重传动齿轮装置 Bracket swing gear assembly	B	
吊杆起重齿轮传动装置 Derrick gear assembly	B	
转向齿轮传动装置 Steering gear assembly	B	
行走齿轮传动装置 Moving gear assembly	C	
<b>挖泥机类 LAND DREDGER</b>		
筒式传送机 Drum-type conveyer	C	
筒式转动轮 Drum-type rotation wheel	C	
挖泥头 Dredger head	C	
机动绞车 Powered crab	B	
泵 Pump	B	
泵转向齿轮传动装置 Pump turning gear assembly	B	
行走齿轮传动装置 (履带) Moving gear assembly ( apron wheel )	C	
行走齿轮传动装置 (铁轨) Moving gear assembly ( track )	B	
<b>食品工业机械类 FOODSTUFF PROCESSING MACHINERY</b>		
灌注及装箱机器 Placer or box filler	A	
甘蔗压榨机 Cane crusher	A	
甘蔗切断机 Cane cutter	B	
甘蔗粉碎机 Cane crasher	C	
搅拌机 Mixer	B	
酱状物吊筒 Paste bucket	B	
包装机 Packager	A	
糖甜菜切断机 Beet slicer	B	
糖和甜菜清洗机 Beet washing machine	B	
<b>发动机及转换器类 MOTOR AND CONVERSION EQUIPMENTS</b>		
频率转换器 Frequency converter	C	
发动机 Motor	C	
焊接发动机 Welding motor	C	
<b>洗衣机类 WASHING MACHINE</b>		
滚筒 Rolling drum	B	
洗衣机 Washing machine	B	
<b>金属滚轧机类 METAL ROLLER MACHINE</b>		
钢坯剪断机** Steel cutter	C	
链式输送机** Chain converter	B	
冷轧机** Cold mill	C	
连铸成套设备 Continuous casting equipments	B	
冷床** Cold bed	B	
剪料机头** Cropper	C	
交叉转弯输送机** Cross steering transmitter	B	
除锈机** Druster	C	
重型和中型板轧机** Heavy and medium steel mill	C	
棒坯切轧机** Bar mill	C	